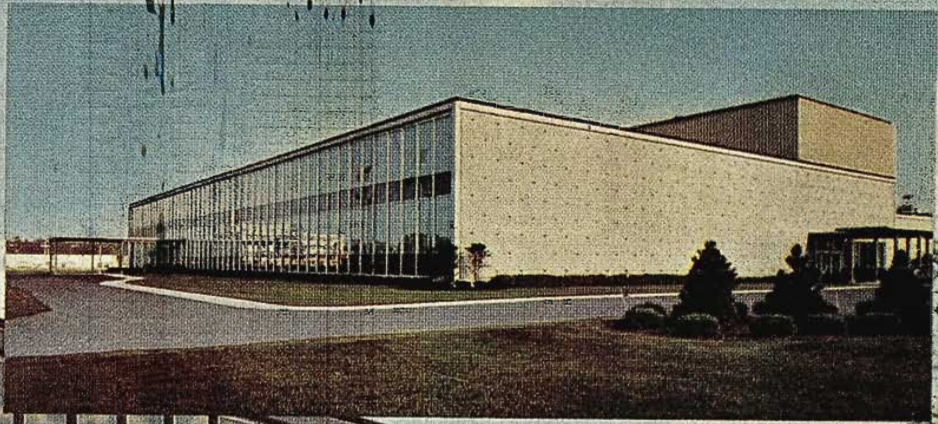


# BROADCAST NEWS



## "COLOR HOUSE"

CONCEIVED, DESIGNED AND  
BUILT FOR COLOR TELEVISION



Vol. No. 112  
DECEMBER 1961



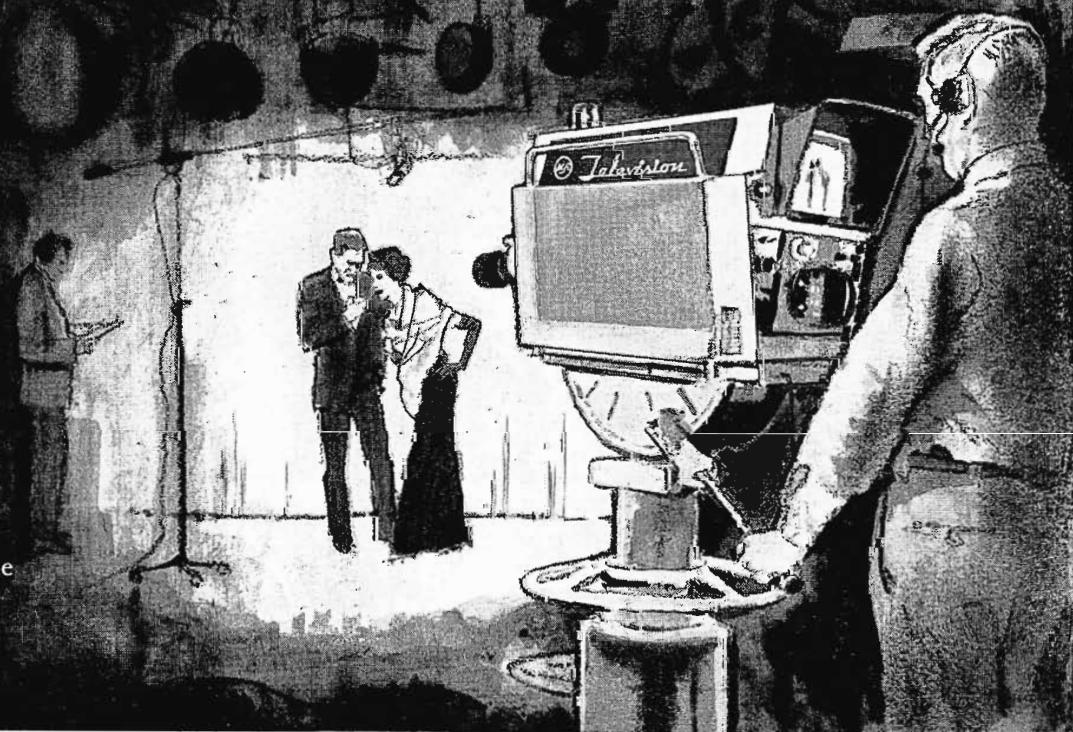


As well known to the Station Man  
as his own Call Letters...

... the mark of  
the finest in equipment  
such as the new 4½ inch  
image orthicon camera—the TK-12.



The Most Trusted Name  
in Broadcasting.



# BROADCAST NEWS

published by

**RADIO CORPORATION OF AMERICA**  
BROADCAST & COMMUNICATIONS PRODUCTS DIVISION, CAMDEN, N. J.

issued quarterly

PRICE in U.S.A. - - - - - \$4.00 for 4 issues  
outside U.S.A. - - - \$5.00 for 4 issues

## C O N T E N T S

	Page
DR. ENGSTROM ELECTED PRESIDENT OF RCA . . . . .	4
FETZER'S WJEF-FM GETS 500,000 WATTS ERP . . . . .	6
FCC TESTS METROPOLITAN COVERAGE OF UHF . . . . .	7
KTTS TELEVISION CENTER . . . . .	8
NEW COMPACT TV TAPE RECORDER . . . . .	12
HOW TO ALIGN MICROWAVE ANTENNAS . . . . .	16
NEW 20-KW FM TRANSMITTER . . . . .	20
NBC COLOR PROGRAMMING . . . . .	24
NEW 5-KW VHF TV TRANSMITTER . . . . .	26
POWER LOSSES IN TOWER ANTENNAS . . . . .	33
WGN COLOR HOUSE . . . . .	36
HOW WBTV GETS LONGER LIFE FROM HEADWHEELS . . . . .	47
KFVS-TV TRANSMITS FROM WORLD'S TALLEST STRUCTURE . . . . .	48
QTQ AUSTRALIAN TV STATION . . . . .	50
NEW MICROPHONE-AMPLIFIER COMBINATION . . . . .	58

### *As We Were Saying*

"ENGINEERS ARE VIPS, we've said it before, we'll say it again." These brave words appeared as a paragraph head in this column in the September 1952 issue. We don't know when we first said it, but we've said it often since. Mostly, of course, we were referring to the fact that station engineers are very important people in station planning, and operation.

This issue we'd like to vary the routine and point out that they are also very important people in RCA. As noted on Pg. 4, our new president is Dr. E. W. Engstrom, who—although his duties in recent years have been administrative—is by upbringing, by experience, by demeanor and, we suspect, by inclination, an engineer. In fact, we might claim him as a broadcast engineer since

*As We Were  
Saying*

most of his years of engineering experience were with radio and television equipment.

Another near-broadcast engineer in high place is Dr. George H. Brown—well known to broadcasters through his many articles in BROADCAST NEWS, and other illustrious publications (sic). George is now Vice-President, Research and Engineering—which, in plain English, means he now oversees RCA's whole technical effort.

Still another broadcast engineer who has made it is our very own Veep, Charlie Colledge. Mr. C. was a real working broadcast engineer, first with CBS, later with NBC. He was in charge of RCA's color field tests in Washington from 1949 to 1951, moved up to VP, Facilities Operation for NBC before coming to his present position as Division Vice-President and General Manager, Broadcast and Communications Products Division.

Someone, surveying RCA's new lineup, said, "Boy, it's like the good old days." We don't know exactly what they had in mind, but we admit to a kindred thought.

**MORE OLD FRIENDS** appear in this issue—to wit, Ward Quaal, Carl Myers, Woody Crane, G. W. Lang and the rest of the staff of WGN. We don't know just when Carl started building broadcast stations. We do remember that he was hard at it—as chief engineer for WGN—at the time BROADCAST NEWS was born. Then, as now, he was one of our best friends (and severest critics). WGN hasn't always used all RCA equipment. But, on the whole, most of it has been RCA—and we're proud of that. It enables us to keep saying "most of the best stations use mostly RCA equipment."

**CIRCULAR STUDIO BUILDINGS** are beginning to catch on. Several have been built recently—and more are "on the boards." This is very interesting to us. Way back in 1950—when TV broadcasting was an infant—we published a series of articles on "The Requirements of Television Station Design" by Dr. Walter J. Duschinsky (BROADCAST NEWS, Volume 61-64). The essence of Duschinsky's ultimate design for "the station of the future" was the circular studio with the control room, etc., in a center area. We thought it was a real good idea. Many of our readers were intrigued—some used part of the concept. But, on the whole, nothing much happened. Now—suddenly—there is a resurgence of the idea. It's pleasant to say we told you so—eleven years ago.

**CORNBERG, TOO**, should be mentioned while we're talking about "where you saw it first." Not quite so long ago—December 1955, to be exact—we published an article entitled "Space Control Production Area" by Sol Cornberg, then Director of Studio and Plant Planning for NBC. Sol's ideas—which dealt mostly with arrangement and facilitating of the production area—were also considered to be a bit "out in the blue," but some

of these ideas have been at least partially adopted—and we believe more will be used in the future. Anyway, we would sooner be ahead of the parade than behind.

**DO YOU WANT MORE** of this kind of article—the avant-garde type, if you will? If so, let's have some "feed-back." All we need is a little encouragement.

**SEE YOU AT NAB** in the same space we've occupied for many years. The "RCA space" they call it—right at the foot of the stairs from the lower lobby (where you register). The Hilton has expanded, and there is a new section of the exhibit hall under the new hotel wing. We chose to stay in the "old" section of the exhibit hall because it's handier, because that's where you are used to finding us—and because it appeared that it would be easier to get heavy equipment in and out. So look for us in the old stall—from noon on Sunday, April 1, 'til 6:00 P.M. the evening of April 4. This is your best opportunity of the year to see what's new in equipment "all under one roof"—as they say. As usual we'll have our engineers in attendance to answer your questions. And we'll do our best to maintain a relaxed atmosphere—no hurry, no pressure, no obligation. Come as often as you can, stay as long as you wish.

**AL JOSEPHSEN** is a little put out with us. Seems we forgot to insert in the last issue a note about his new swimming pool, and an invitation to all his old friends to come visit him. Since his retirement a year ago, Al just doesn't have anything to do—nothing that is except drink booze, sit in the sun, swim in his pool, paint, work in his garden—and do a million things the rest of us vaguely hope to do some day. But Al says he really misses the noise, the confusion, the pressure (the Copenhagen?)—and most of all he misses his legions of friends. His address is 1860 Grace Avenue, Fort Myers, Florida. He says come whenever you can, stay as long as you can—but BYOB (he's no longer on expense account!).

For the few of you who don't know, Al is a legend in RCA—and in much of the industry. He retired last year after a forty-year career with RCA—the greater part of it as a broadcast equipment salesman, first in California and the southwest, later in the midwest, and for the last fifteen years in New York.

Al's exploits as a salesman were many—and some are still related with awe. Young engineers quaked in his presence—and vice-presidents were careful not to arouse his ire. But mostly he is remembered as the kind of salesman that customers loved—and so did all of us at RCA. Probably no salesman ever made so many friends for himself, and for RCA. Certainly none worked harder, more loyally, or for so long. His forty-year record will stand for a long time.



## *As We Were Saying*

**THIRTY YEARS OF BROADCAST NEWS** will be marked by this single — and, we hope, not too lachrymose page. Ten years ago, on the occasion of our twentieth year, we devoted nearly a whole issue to reminiscing. Such “looking backward” is no longer fashionable — and maybe its just as well. Nevertheless, there may be some readers who are interested in how and why BROADCAST NEWS was started. The following paragraphs are just for them.

The first issue of BROADCAST NEWS was mailed in mid-October, 1931, to the 700 stations then on the air. The great majority of these stations were of “composite” manufacture. Many of them were really “home-made” in the homiest sense of the word. This was not surprising, for many, if not most, of the broadcast stations taking the air during the twenties did so by the grace, if not the inspiration, of some aspiring amateur. However, by 1931, quite a few stations were making money (a development which originally came as something of a surprise). As the cash registers started ringing broadcasters stopped looking on their stations as hobbies, or prestige operations, and began running them like businesses. That’s where we came in.

RCA had started selling broadcast equipment in 1927, but did not aggressively go after the market until its manufacturing operation was established in Camden, N. J., in 1930. In the early part of 1931 there were just 30 RCA transmitters on the air. Six RCA transmitter salesmen were running themselves ragged trying to sell all the other 670 stations on the advantages of RCA equipment.

It soon became evident that in order to get information about our new equipment out to 700 stations in a hurry we would need some other means to augment personal calls. But how?

The answer we arrived at was BROADCAST NEWS—our own magazine, for our own customers (and fair prospects). A magazine devoted to the interests of broadcasters — particularly those of a technical bent — and carrying only information of interest and usefulness to them.

The selfish purpose of BROADCAST NEWS, of course, was to present information on our equipment, its uses, its advantages, and its operation to the broadcast station engineers who are RCA’s customers. That was, and still is, the primary purpose of this publication. However, it was recognized from the first that the magazine could at the same time serve the broader purpose of providing (as was noted on the title page of the first issue) “a pleasant and convenient medium for the exchange of ideas and information” among broadcast engineers everywhere. To this end the articles printed in BROADCAST NEWS have not been limited to those authored by RCA personnel but, from the first, have included arti-

cles by station engineers, consultants and others. Moreover, the subjects discussed have included many not directly related to RCA equipment. The happy result is a publication which serves our engineer-customers (by helping them in their work) while at the same time serving us by publicizing our products.

As a result of this policy, broadcast engineers early accepted BROADCAST NEWS as an ally in their work, and have supported it not only with letters of approval but, more importantly, by contributing to its pages. Other members of the industry—including some of the best-known consultants and designers—have done likewise.

The subject matter, over the years, has touched almost everything of interest to station engineers. Only one limitation has been imposed. It was early decided that BROADCAST NEWS was properly concerned *only* with broadcast equipment design, installation and operation. While broadcast engineers certainly have other—and wider—interests, it was felt that these were adequately covered in general magazines. On the other hand, broadcast equipment per se, received relatively little attention in the radio journals existing in 1931. And even today, the trade journals devote relatively little space to the technical side of broadcasting. BROADCAST NEWS, at least to a degree, fills the gap. By strictly limiting its coverage to the subject, it is able to print far more information on broadcast equipment than can be found anywhere.

During its thirty years BROADCAST NEWS has had five editors, numerous assistant editors, and literally scores of editorial advisors and consultants. Many of these have lavished on it time and effort far beyond the possible return in either pay or glory. Were BROADCAST NEWS a private publication, this thirtieth anniversary issue would nostalgically note their names and credits. But BROADCAST NEWS is not a personal organ—rather it is the symbol of a very special business—the broadcast equipment business of the Radio Corporation of America. Thus the important thing in its thirty year history is not the names of the many individuals who contributed to it, but—almost contrariwise—the fact that despite individual comings and goings, depression and boom, freeze and unfreeze, war and near-war, it has held steadfastly to the policy that was set down thirty years ago.

In doing so it has reflected the continuity, the stability, the foresight of the RCA Broadcast Equipment Department. Only for this reason is the thirtieth anniversary of BROADCAST NEWS important.

For the future, we propose to concentrate our efforts on making BROADCAST NEWS of more widespread interest and of greater usefulness to both radio and television broadcasters.



# DR. E. W. ENGSTROM ELECTED PRESIDENT OF RCA

Twenty-seven years ago there appeared in BROADCAST NEWS a brief column (below) about a quiet, dedicated young scientist who was just beginning to make his mark in RCA. Last month this quiet, dedicated, still-young-looking, scientist-turned-administrator was elected President of RCA.

In the years between Elmer Engstrom had successfully directed RCA's quarter-century effort to develop and perfect television, marshalled RCA's research abilities during World War II, directed RCA's ten-fold increase in defense electronics following Korea, and organized the company's push into space electronics.

He had been, successively, Director of General Research, Vice-President in Charge of RCA Laboratories, Executive Vice-President in Charge of Research and Engineering, and, since 1955, Senior Executive Vice-President with responsibility not only for all research and engineering but also for direction of the Corporation's all-important defense and space operations.

The announcement of Dr. Engstrom's election as President was made on December 1, 1961, by Brig. Gen. David Sarnoff, Chairman of the RCA Board of Directors. It was an announcement which he obviously relished making—for Dr. Engstrom is very much in the pioneering tradition established for RCA by the General himself. It was an announcement which was greeted happily throughout the company—for, as many pointed out, "He's one of us." And it was an announcement which was welcomed by an industry which had come to recognize Dr. Engstrom as one of its most respected leaders.

To everyone in RCA, and to most of the industry, it seemed "very right" that Elmer Engstrom should become President of RCA. In fact, it was so right that, curiously, most people were somewhat surprised when it actually did happen.

Possibly Dr. Engstrom was a little surprised, too. Certainly, the quiet, courteous young scientist pictured in that early BROADCAST NEWS column did not then envision himself in the President's chair. Perhaps he did not even expect to become the top engineer in RCA. The odds seemed against it. The 1934 "Who's Who" column (the first of a series) carried stories on three engineers. The first two were W. R. G. Baker and Dr. V. K. Zworykin. "Doc" Baker was then Vice-President in Charge of Engineering, and Dr. Zworykin was already famous for his invention of the iconoscope. But who was this third man, Engstrom? Outside of the Camden laboratories few had ever heard of him.

It was only by some remarkable prescience of the editor that he was included. For at that time, and for some years after, he was surrounded by better-known men of great talent—the top engineers of radio's early days, brought together in Camden when the radio engineering and manufacturing activities of General Electric and Westinghouse were transferred to RCA in 1930. Moreover, these were not only giants of genius—but men of independent and tempestuous ways. No one who knew that curious menage would have prophesied that the quiet young man with the cherubic countenance would

**BROADCAST NEWS**  
REG. U. S. PAT. OFF.

**IN THIS ISSUE**

A VISIT TO THE NEW WLW  
By J. R. Baker

BYRD ANTARCTIC EXPEDITION  
PROGRAMS FROM SOUTH POLE  
By H. A. China

ADMIRAL BYRD BROADCAST PICKUP  
By D. B. Templeton

NEW ART IN RADIO  
An Outline of John Vestos

PROGRAM AMPLIFIER 1934 DESIGN  
By Edmund Frost

IMPORTANCE OF FIELD STRENGTH  
SURVEY  
By William L. Foss

POLICE RADIO NEWS  
—And a Dozen Other Interesting Features

**RCA Victor Company, Inc., Camden, N.J.**

NUMBER 10      PRICE 25 CENTS      FEBRUARY, 1934

FEBRUARY, 1934

35

## Who's Who at "Radio Headquarters"

As there were then no A. C. operated sets, and a storage battery was an inconvenience in the household. He also took part in the design of the first A. C. vacuum tube. Later he turned his attention to mercury vapor rectifiers and photoelectric cells and also devised a useful type of Kerr cell. Many fundamental principles and important features of the modern sound movie equipment were the outcome of his work.

Facsimile equipment for the transmission and reception of photographs, drawings, maps and various other types of pictures— even including the written or printed page—was perfected under the direction of Dr. Zworykin.



DR. VLADIMIR K. ZWORYKIN,  
RESEARCH ENGINEER, RCA VICTOR CO., INC.



E. W. ENGSTROM,  
RESEARCH ENGINEER, RCA VICTOR CO., INC.

BORN in Russia in 1889, Dr. Vladimir K. Zworykin was trained in electrical engineering at the St. Petersburg Institute of Technology, and subsequently continued his studies in Paris, under Professor P. Langevin, in the College de France.

At the beginning of the World War, he returned to Russia and entered the Signal Corps of the Russian Army, where he engaged in the development of radio equipment for aircraft.

At the conclusion of the war, Dr. Zworykin moved to the United States and was engaged by Westinghouse Electric and Manufacturing Company at East Pittsburgh, in their research laboratory, specializing in vacuum tube work. Dr. Zworykin played an important part in the development of the first dry battery operated vacuum tube for broadcast receivers—the pioneer Radiotron W1D 11, which became very famous in the early days of broad-

IN 1923 the University of Minnesota graduated E. W. Engstrom, who immediately went to work for the General Electric Company at Schenectady, New York. Here he was associated with research work on radio transmitters until early in

1926, when he began research work on radio receivers. He later was placed in charge of a newly formed section organized for the purpose of performing research work on sound motion picture equipment, and he was very active in the early days of the sound-on-film system which was destined to become world famous as the RCA Photophone System.

In 1930, when all research, development and manufacturing work of the RCA Victor Company was concentrated at "Radio Headquarters" in Camden, N. J., Mr. Engstrom was transferred to the Engineering Department of this plant, and placed in charge of the work corresponding to that in which he had previously engaged at Schenectady.

In 1931 he became responsible for radio receiver and phonograph research work and he subsequently has been placed in charge of the research activities of the RCA Victor Company at "Radio Headquarters."



some day rule the lion cage—and that he would go on from there to run the greatest electronic company on earth.

But this young man was not only a scientist—he was also an astute organizer and administrator. The exigencies of television development soon brought this to light. Elmer Engstrom's first research group was relatively small. But things were moving. It was 1931, and RCA was about to make the first "field test" of a complete television system. Elmer Engstrom—having already served apprenticeships in transmitters, in receivers, and in sound motion pictures—was ready. The Empire State Building was invaded (the first of many times) and a transmitter installed on the 85th floor. A mechanical scanner provided a 120-line, 24-frame picture from live and film subjects. Extensive field tests were made using the first cathode ray tube receivers. The pictures left much to be desired but the equipment worked well as a system—and the tests proved that a television broadcasting service was, indeed, possible.

It was a milestone in television development—and the quiet young scientist had played an important part. For the next twenty years he was to be in the very center of RCA's television development—and to take an increasingly important part in it. His research responsibilities were gradually broadened to include apparatus, systems, and tubes. By the time RCA was ready to introduce television to the public, at the World's Fair in 1939, he was in charge of all research for the RCA Manufacturing Company.

In 1942, when the research activities of RCA were brought together at Princeton, N. J., Dr. Engstrom was appointed Director of General Research. The war was on—and the job was to organize the diverse talents of all the Laboratories' bright stars. It was not easy. But Elmer Engstrom had worked with these engineers and scientists during the early television experiments. He knew what each could do—and how to harness their various abilities to best advantage. Under his direction the research group of RCA Laboratories compiled a brilliant war-time record in radar, shoran, sonar, airborne television, infra-red, radio thermics and many facets of communications.

With the end of the war came the problem of reorienting to peacetime pursuits. Television again became the big thing in electronics. A flurry of new stations was followed by a "freeze" while the industry and FCC settled the question of standards—first for monochrome, and then for color. During the interminable field tests, hearings and reviews, Elmer Engstrom directed RCA's technical efforts and acted as the Corporation's chief spokesman. He also served as Vice-Chairman of the NTSC—the industry committee which studied and recommended the standards eventually adopted by the FCC.

His abilities—by now well recognized within RCA—began to be noticed by others. In 1949, New York University conferred on him the honorary degree of Doctor of Science. Interestingly, the citation read (in part): "Elmer W. Engstrom . . . one of that exclusive group of latter-day Prometheans who not only illumines with his own brilliance, but who yokes his fellow Titans unrenowned for tractability into corporate resourcefulness and fecundity." Truer fifty-cent words have seldom been written—for Dr. Engstrom's great ability is, indeed, to recognize, organize and direct the proliferating talents which surround him.

This has become even more evident in the ten years since the NYU citation. In 1951, he was made Vice-President in Charge of RCA Laboratories and in 1954, he was given the additional responsibility for all engineering throughout the Corporation. His big step upward came in 1955, when he was also placed in charge of RCA's Defense activities. Spurred by the experience of Korea, a tremendous build-up was taking place in defense electronics. Dr. Engstrom—as he had done previously in television and war-time research—organized all of RCA's abilities into a great team of science, engineering



DR. E. W. ENGSTROM  
President, Radio Corporation of America

and production. RCA's defense business, less than \$50 million annually at the time of Korea, climbed steadily to nearly \$500 million in 1961. Monster projects—such as BMEWS—were undertaken and successfully completed. In 1958, Dr. Engstrom set up an Astro-Electronics Division to give special attention to RCA's projects in space technology. The very successful TIROS weather-reporting satellites were an early product of this division.

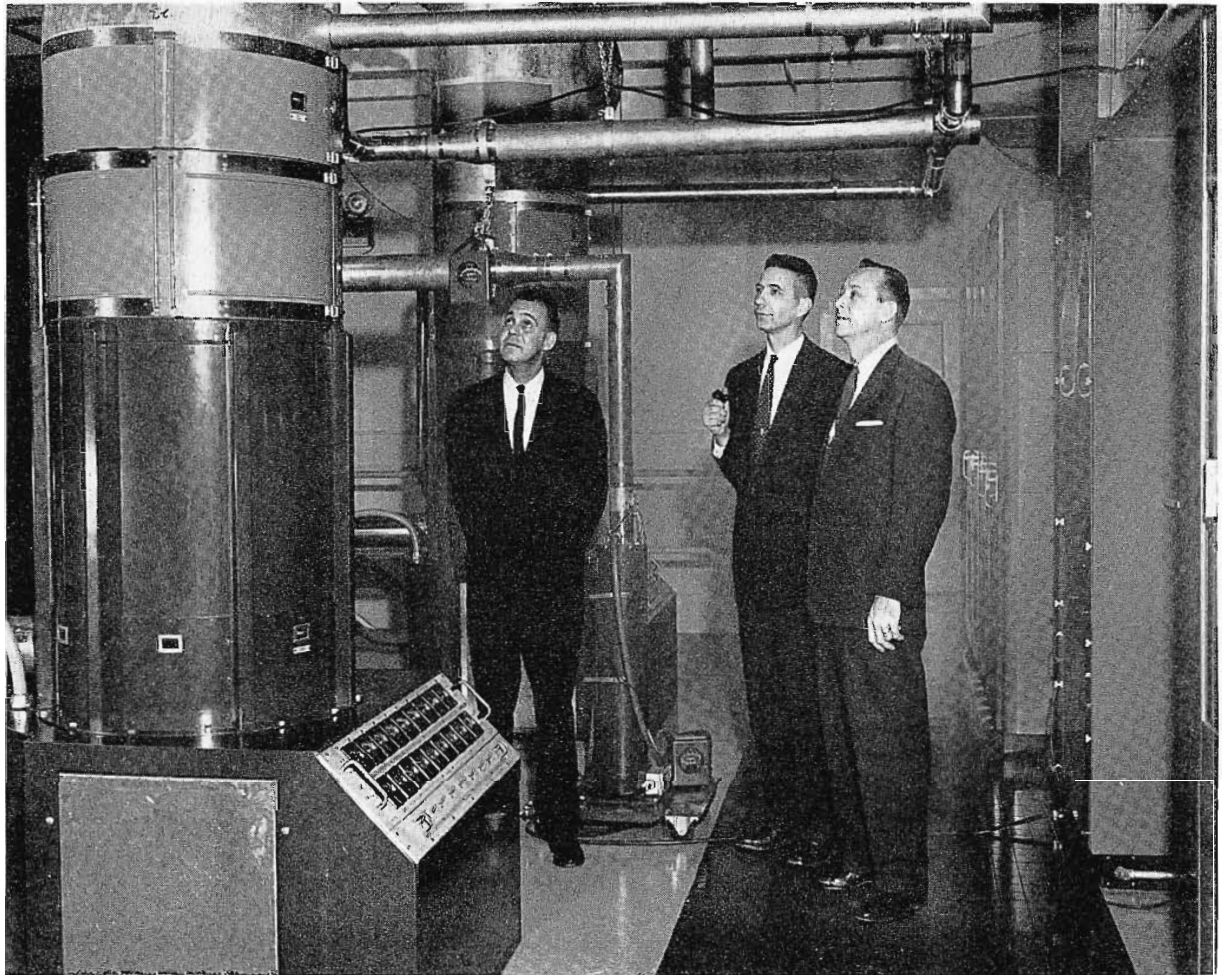
As Senior Executive Vice-President Dr. Engstrom has, in recent years, also had the responsibility for manufacturing and other corporate staff activities. In his new position he will have supervision of all company operations.

What is this prodigious man like—as a person? His steadfastness is his outstanding trait. The picture above suggests that he has not changed very much from his days as a young engineer. Those who know Elmer Engstrom best will tell you that he is, indeed, the same man. More experienced, of course, more mature—but still quiet in mien, courteous in speech, and almost embarrassingly honest in everything he does. He is—as he always was—searching in questioning, and steely eyed in decision-making. He has a natural reserve that is sometimes mistaken for aloofness. But it is noticeable that he remembers and is quick to acknowledge the thousands of acquaintances he has made over the years. And he has made a point of maintaining personal relationships which date back to his days as a young engineer.

Without exception those who have worked with him have not only a high respect for his ability and integrity, but also a genuine liking for the man himself. The unanimity of this regard is overwhelming. The news of his elevation to President was received in various departments of RCA with a reaction which varied from quiet jubilation to unabashed celebration.

Broadcasters, too, should be pleased. Like many BROADCAST NEWS readers he has spent his entire working life in radio, television and related fields—and his career has closely paralleled, and been interwoven with, the development of broadcasting. Certainly Broadcasters can look forward to a strong continuation of RCA's interest in their field.





**FM LUNG POWER**—Checking power amplifier for new 50-kilowatt transmitter at WJEF-FM, Grand Rapids, Mich., the nation's most powerful FM station, is this trio of Fetzer Broadcasting Company executives. From left, Bruce Glycagdis, Chief Engineer, WJEF-AM-FM; Arthur E Covell, Chief Engineer, WKZO-TV, Kalamazoo, and Carl E. Lee, Executive Vice-President, Fetzer Broadcasting. The midwest station uses RCA's new 50-kw FM transmitter and a 12-bay, high-gain antenna to produce 500,000 watts of effective radiated power.

## **FETZER'S WJEF-FM GETS 500,000 WATTS ERP WITH RCA 50-KW FM TRANSMITTER**

A stentorian voice is now heard in the land. It emanates from WJEF-FM, the Fetzer Broadcasting Company station in Grand Rapids, Michigan, which has been newly equipped to become the nation's most powerful FM broadcaster.

Using a combination of a new RCA 50-KW FM transmitter and an RCA 12-section, high-gain antenna, "Jeff" raised its voice in early fall to the allowable maximum of 500,000 watts effective radiated power. It was a banner day for FM's loyal legions of listeners, both in WJEF's area and elsewhere. For, as the first FM station to use an RCA 50-kilowatt transmitter, WJEF is leading what appears to be a trend toward higher FM powers. And it is evident that higher powers, in turn, will help along the current resurgence of FM broadcasting.

Even while city dwellers and rural listeners were settling down to cozy winter evenings (actually 20 hours daily) of WJEF-FM's pleasant

fare, station management was preparing a new broadcasting treat. It has begun installing stereo transmitting equipment preparatory to taking the air at an early date with the newest in radio service.

WJEF's voice speaks from an antenna mounted 800 feet up on the 1,000-foot tower of Fetzer's television station, WKZO-TV, located midway between Kalamazoo and Grand Rapids. The transmitter which gives power to WJEF-FM's voice has a rather familiar look to TV broadcasters who visit the plant. And well it should—for the output stage consists essentially of two of the aural sections of an RCA 25-KW TV transmitter (see above). The two amplifiers are driven in parallel by an RCA 10-KW FM transmitter.

The WJEF-FM transmitter is located in the same room as the WKZO-TV transmitter—making this one of the most imposing transmitter installations in existence. We hope to describe the complete installation in detail in a forthcoming issue.





**UHF START-UP**—Hand at the switch, Chairman Newton N. Minow of the Federal Communications Commission officially puts television station WUHF on the air in New York. Observing the November 29 start-up ceremony are (right) C. H. Colledge, Division Vice-President and General Manager for RCA's Broadcast and Communications Products Division which leased and installed the transmitter in the Empire State Building, and (center) Seymour N. Siegel, Director of New York City's Station WNYC, which operates WUHF.

## **FCC TESTS METROPOLITAN COVERAGE WITH RCA 50-KW UHF TRANSMITTER**

Another RCA 50-KW transmitter found itself a key figure in a drama played out November 29 eighty floors above New York streets clogged with Christmas shoppers.

The transmitter was the TTU-50A, the most powerful ever built by RCA for UHF television service; the locale was the FCC's experimental UHF TV station, WUHF, transmitting from the Empire State Building, and the featured player was FCC Chairman Newton Minow, there for a switch-throwing ceremony that was to put WUHF officially on the air.

In a room brightened by news photographers' flash bulbs, the switch was thrown and the transmitter responded by generating a signal for the new Channel 31. Thus began an experimental transmission, to run until next June 30 or beyond, to test UHF television coverage over a large metropolitan area.

For RCA, the event climaxed weeks of carefully-planned logistics involved in moving the heavy equipment up elevators to the high perch. The transmitter was connected by a 9 $\frac{3}{8}$ -inch transmission line to the antenna atop the building.

The work was performed under a leasing and installation contract awarded by the FCC last March 1. At the time the Commission said the award was made "after the Commission considered competitive proposals on the basis of power consumption, tube replacement, experience in installing and general performance as well as cost."

Under a separate agreement, RCA supplied an array of studio equipment to WNYC, the New York City-owned station which will handle programming for the FCC outlet. This included four field TV camera chains for studio or remote use, a film camera and associated projector facilities and an RCA TRT-1B television tape recorder.



# FROM "2nd STORY" OPERATION TO 10-ACRE TELEVISION CENTER

How Vision, Ingenuity, Dedicated  
Personnel and RCA Equipment  
Brought KTTS-TV to the Ozarks

by E. PRINGLE THOMAS, *Promotion Director*  
*Independent Broadcasting Co., Springfield, Mo.*



FIG. 2. Typical "prop" problem encountered when KTTS-TV was located on second floor of downtown building.

FIG. 1. New 20,000 square foot Television Center of KTTS-TV.

When the management of KTTS Radio in Springfield, Missouri, decided to add television to the operation back in 1952, a great many people said it couldn't be done. Not the way it was planned at any rate. It was impossible, they said, but granting it was possible, most impractical to establish both studio and transmitter on the upper floor of an old, downtown building already crowded with radio equipment.

Such negative opinions were not shared by G. Pearson Ward, Vice-President and General Manager of Independent Broadcasting Company and Chief Engineer William F. "Bill" Curry, however. With the

same enthusiasm that characterized the establishment of KTTS Radio ten years earlier, but tempered with typical Ozark caution, the challenging task of planning and building the area's first television station began.

The KTTS-TV Channel 10 permit was granted on September 9, 1952, and the station went on the air March 14, 1953. In the intervening six months the entire upper floor of our downtown building had to be remodeled and made ready. Equipment had to be ordered. Additional engineering personnel had to be hired and trained and a thousand and one other de-

tails finalized . . . such as the erection of a new tower on an old building in the center of the business district with its many limitations and restrictions.

#### Temporary Antenna Installed

The existing tower used by KTTS Radio was removed and replaced with a heavy, maximum height 150 foot tower with a RCA 6 section antenna bringing the total height to 238 feet above average terrain. But in the beginning, the first broadcast was transmitted from a temporary 100 foot tower, guyed to poles and adjacent buildings. The installation of the new tower was



accomplished over a weekend without loss of broadcast time. It was placed on the old supports which in 1942 had been constructed six feet below the basement level with the tower projecting through the entire three floors of the building to the roof.

### RCA Equipment Received and Installed

The original RCA equipment, which consisted of a 2-kw transmitter, 6 bay antenna, a TP-16-B film camera chain, one studio camera and an RCA terminal equipment package was installed as each piece arrived. It may be interesting to note that the then new, RCA Teflon 50-ohm line to transmitter and antenna was used.

A room, approximately 15 feet wide and 22 feet deep, housed the master control, terminal equipment, projectors and film department. With careful maneuvering, there was just enough space to enable switchers, producers, projectionist and film editor to work in "close" harmony and to slip in an occasional sponsor, program director or engineer.

In spite of the difficulties and problems encountered during the six month installa-

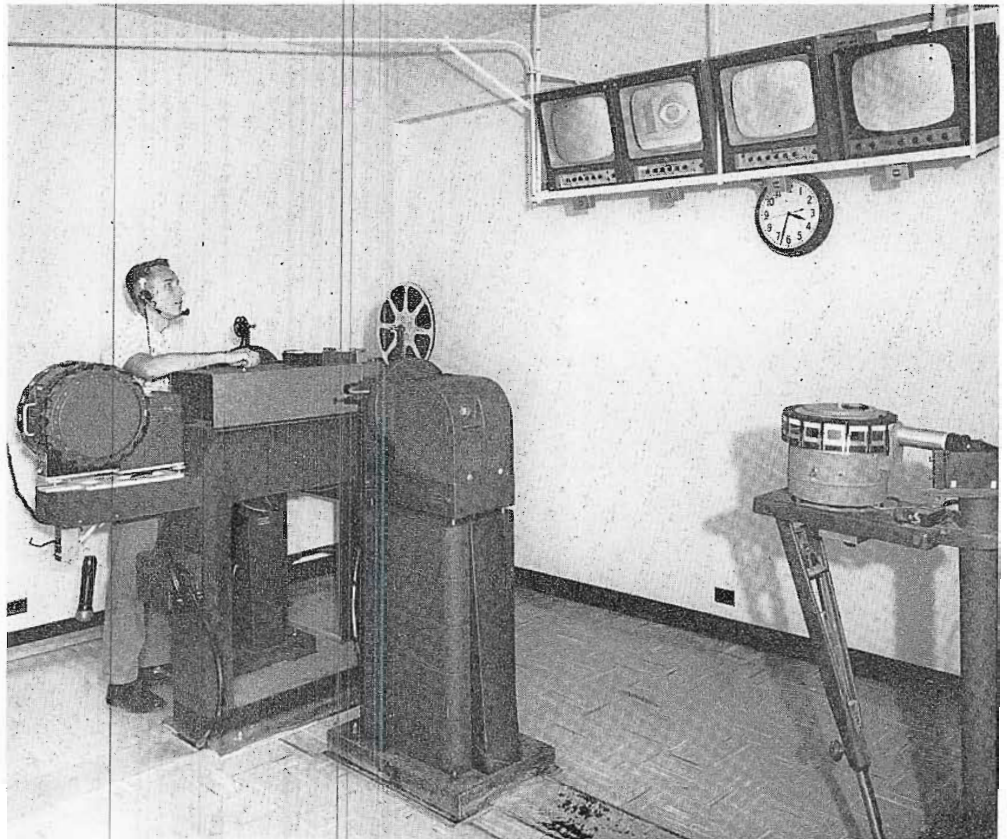


FIG. 4. Television film projection room of KTTS-TV.

FIG. 3. Main television studio provides 4800 square feet and is completely equipped.



tion period, KTTS-TV, Channel 10 succeeded in broadcasting the first television program to the Ozarks on March 14, 1953, with a power of 12,500 watts, and it operated successfully and at a profit, under these circumstances and with the original transmitter, antenna and equipment, until March, 1956.

### Props Pose A Problem

During these first three years of broadcasting, programming was hectic, hurried and often humorous. Since there was no elevator in the building, all of the tons of refrigerators, freezers, air-conditioners, washing machines, television sets, dairy cases, furniture and other merchandise shown on live camera, had to be carried up three flights of steps into the studio, and carried back down again. Upon one occasion, a sponsor gave away a quarter horse with the suggestion that it be shown on camera. It was, as is evidenced by the insert picture in Fig. 1. It took a program director, six stalwart men and a studio guest to get the animal up 33 steps to the second floor and at times, during the process, it looked as if the policy of the new television station: "The difficult we do now . . . the impossible takes a little time," might be broken. But the horse appeared on camera as scheduled.



Another time, a troupe of trained seals from the Shrine Circus were the guests of Channel 10 and for weeks after, the studio had the peculiar odor of a fishing schooner.

### 87 Live Programs Per Week

At the feverish height of this one camera broadcasting period, KTTS-TV broadcast 87 live local programs per week, plus an average of 35 live commercials per day.

But plans had been made in the beginning that these crowded and sometimes crude conditions would not always prevail. Ten acres of beautifully wooded land had been secured east of Springfield but within the city limits. It was situated adjacent to a large private airport.

Work was begun on a new transmitter building on this site and plans for a functional Television Center drawn up for completion late in 1959.

In March, 1956, the new transmitter was completed and the switchover from the downtown location was made. KTTS-TV now operated on a maximum power of 316,000 watts, with a 25 kw RCA transmitter, an RCA 12 section antenna atop a 710 foot tower. An RCA TMV-1-A microwave system for STL service had been installed and this was used until 1960, when the network furnished other facilities. Remote facilities were also added and an additional camera purchased.

### Move to New Studios Made

In July, 1959, the new Television Center was ready for occupancy and at 10:30 p.m. August 1, the job of moving began and continued throughout Saturday and



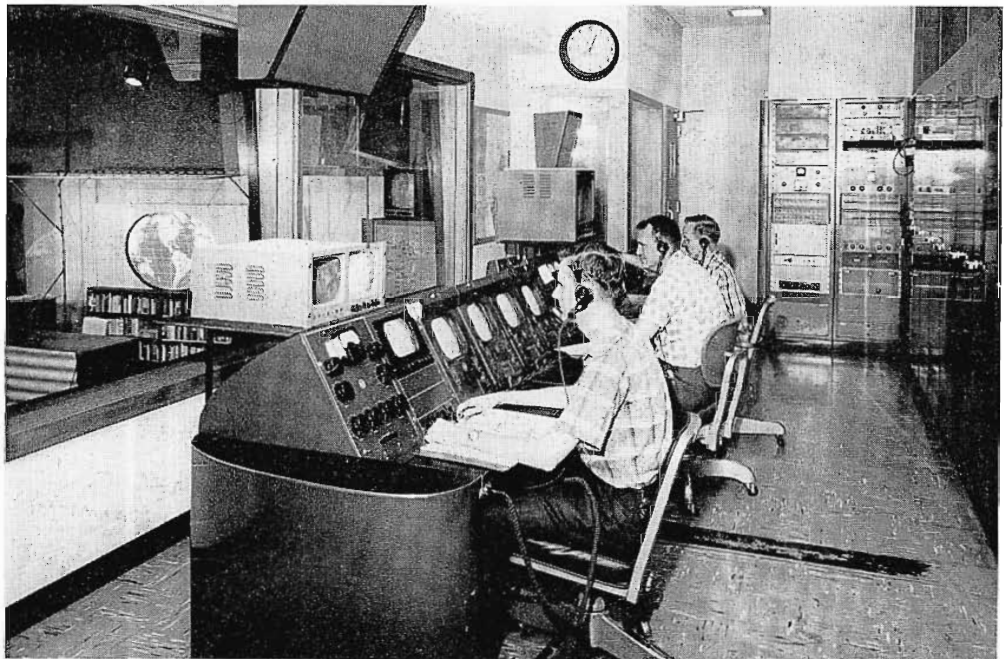
FIG. 7. G. Pearson Ward, Vice-President and General Manager.



FIG. 8. Bill Curry, Chief Engineer.



FIG. 9. Charles L. Lloyd, Sales Director.



▲ FIG. 6. Master Control room of KTTS-TV.

▼ FIG. 5. Television transmitter room showing 25 kw RCA Transmitter (used in conjunction with 12 bay antenna for maximum power).



Sunday. The moving itself was a well planned, smoothly executed project. Each department was responsible for seeing that the office equipment, files, etc., were properly loaded into the moving trucks and set in their right places in the new building. At sign-on Monday morning, all of the 70 or more KTTS employees were at their jobs and not one second of broadcast time had been lost.

### Open House Attracts 8000 Guests

It took a while, as might be imagined, to adjust from a small, upper floor studio to the spaciousness of the new 20,000 square foot Television Center with its 4,800 square foot completely equipped central studio. But adjustment was made and in October, 1959, an Open House was held which attracted over 8,000 visitors. For two days, KTTS-TV personnel conducted small groups of from 10 to 15 per-





FIG. 10. E. Pringle Thomas, Director of Promotion.



FIG. 11. Kevin McAndrews, Program Director.



FIG. 12. Sam Short, Business Manager.



FIG. 13. Bill Bowers, Director of News Department.

sions through the entire plant. On the evening prior to the Open House a Preview Party was held for local, county and state dignitaries and featured a thirty minute live telecast of the proceedings. Over 400 persons attended.

#### Plans for the Future

After two successful years in Television Center KTTS-TV is in the process of planning further improvements and additions that will help it operate even more efficiently and entertainingly in the public interest. A swimming pool has already been added, surrounded by a 4800 square foot concrete patio which will be used for outdoor production of local programs such as the Cooking School, Children's Show and for live commercial production featuring those items that lend themselves to the outdoors.

Redwood dressing rooms and a cooking

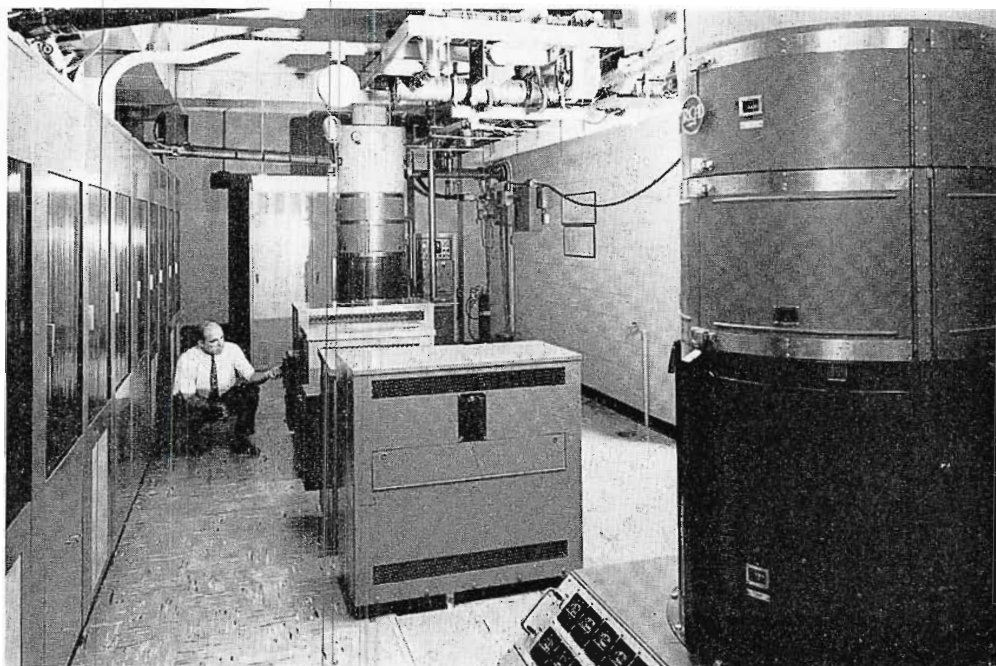


FIG. 15. Rear of TV transmitter showing RCA 25 kw power amplifiers.

FIG. 14. Film Department, showing Ted Tucker, Director, and Barbara Russell, Assistant to Director.



area will be constructed in the spring and plans are being laid now for the construction of a tennis court, badminton and handball courts, golf greens and a Little League ball park . . . all on the 10 acre area and all lending themselves to varied outdoor programming. Distant future plans may even include the creation of a typical Western village.

Whatever the future holds, one thing is certain. The business policies upon which KTTS Radio was founded almost twenty years ago . . . the policies responsible for the growth and public acceptance of KTTS-AM and FM Radio and Television will change only if the changes will make possible a better, more valuable service to the public. That is the basis upon which operating permits are issued. It is the policy that has influenced KTTS progress in the past . . . and that will influence its progress in the future.



# The RCA TR-11

## A "Compact" TV Tape Recorder

by H. H. KLERX

*Merchandise Manager, Electronic Recording Products*



The RCA TR-11 TV Tape Recorder, is now in use at a number of broadcast and ETV stations. This compact unit is a fully compatible quadruplex recorder offering new economies in both price and operating cost. It is designed for monochrome operation by both broadcast stations and closed circuit TV users. The TR-11 is completely compatible with existing equipment. This means the tapes made on other quadruplex broadcast recorders can be played back on the TR-11. Likewise, tapes made on this TR-11 recorder can be played back on any quadruplex recorder.

### Basic TV Tape Design

Design of the TR-11 is based upon that of its senior partner the TRT-1B TV Tape Recorder. Many of the components and design techniques that have made the TRT-1B the top recorder for high quality taping requirements are used in this new compact model. Picture quality from the TR-11 is comparable to TV tape recorders priced much higher. The TR-11 meets and exceeds FCC requirements for "on-air" telecasting. Wherever space or limited funds have delayed the use of TV taping, or where further expansion of existing facilities is desired to handle increased tape recording and playback requirements, the TR-11 "compact" recorder deserves consideration.

The TR-11 is completely housed in three standard equipment racks and occupies only 8.2 square feet of floor space. In order to accomplish this space reduction and offer a lower price, several features standard in the TRT-1B recorder have been omitted. These include the 17-inch picture monitor, the 5-inch oscilloscope, audio cue channel facility, master erase head, RF copy provision, and automatic guide positioning. Also other areas of control and metering functions have been simplified. At the same time, no compromise in picture quality has been made.

Basic features of the TRT-1B such as electronic quadrature adjustment, RF equalization, built-in test switcher (pre-wired to make all important waveform and

FIG. 1. New compact TV Tape Recorder, TR-11, is housed in only three standard equipment racks and requires only 8.2 square feet of floor space. Several new design features have been incorporated to achieve space reduction while retaining excellent quality performance.



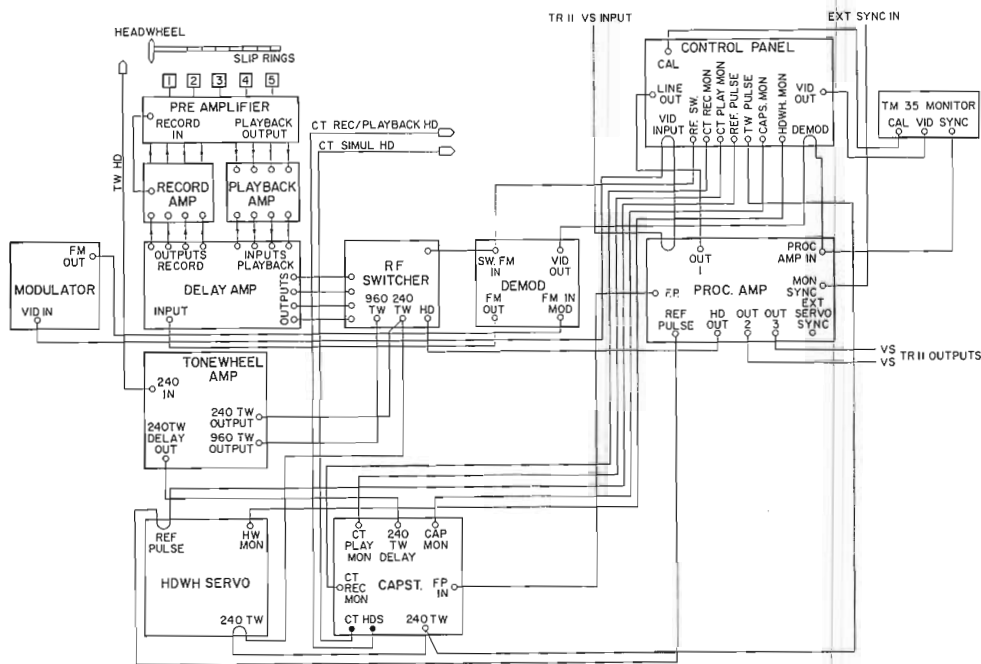


FIG. 2. Video functional diagram of the TR-11 compact TV Tape Recorder.

picture signals available for ease of setup and operation), simultaneous audio and control track playback, and remote control have been retained in the TR-11 to assure high standards of performance.

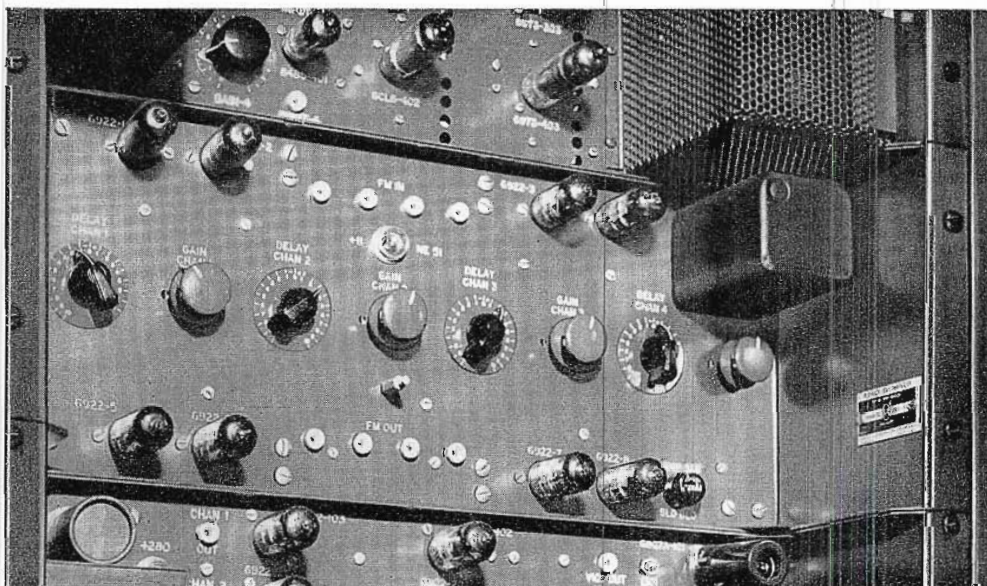
#### New Features

Those familiar with the TRT-1B recorder will note the design similarity shown in the TR-11 video functional diagram, Fig. 2. Innovations which have been included in the new design are a switchable record/playback delay-line chassis, a 4 by 1 switcher, sync separation module for the processing amplifier, simplified control panel, and a manual control for mechanical positioning of the vacuum guide.

#### Single Chassis Record/Playback Quadrature Delay

The record/playback quadrature chassis, Fig. 3, is similar to the playback unit on the TRT-1B and is equipped with a ganged rotary switch that automatically transfers the proper quadrature correction when the TR-11 is in record mode. Thus, this single chassis performs quadrature correction functions in both record and playback modes. While the operator has the ability to correct quadrature on improperly recorded tapes during playback, he must exercise caution to return the quadrature knobs to their original settings whenever he wishes to record.

FIG. 3. Single chassis is used for manual control of both record and playback quadrature correction.



#### 4 by 1 Switcher

A newly designed 4 by 1 switcher, Fig. 4, performs the functions of both the 4 by 2 and 2 by 1 switchers in the TRT-1B. The design of the switcher incorporates a transistorized 4 by 2 circuit board on the 2 by 1 switcher chassis, which also includes the variable head equalizers. The redesign, however, eliminates the sync separation function from this unit.

#### Sync Separation Module

The sync separation function is contained in a transistorized module which mounts in the processing amplifier as shown in Fig. 5. This module also includes reference generator and frame pulse generator functions. The circuits perform identical functions as similar circuits in the TRT-1B recorder. In addition, they have the ability to handle most non-standard sync, such as that used in many industrial-type television cameras.

#### Simplified Control

The simplified control panel retains basic tape control functions and also includes a simplified monitor switcher. Five video, two audio and five speaker/meter selector controls are provided. Operating controls include electrically interlocked momentary-contact position buttons for record, play, stop, fast forward, and rewind. All have illuminated tallies. There is also a control track phase adjustment and a head hour indicator and audio and video gain controls.

Monitoring facilities include: (1) a small switchable continuity speaker and associated amplifier, (2) a record current panel meter which indicates the individual video recording head currents on a switchable basis, and (3) a VU meter which has ASA standard characteristics and which indicates program audio input and output levels, audio channel erase current, audio channel record level and control track levels. All of the operating functions are illustrated in Fig. 6.

The panel adjacent to the control panel provides space for mounting an accessory TM-35 master monitor, if desired. Included on this panel is a microphone input. The microphone is used in initial setup of the recorder and feeds the audio channel directly. Once setup has been accomplished, this audio information is automatically erased prior to recording program audio on this dual-purpose channel.

#### Manual Vacuum Guide Adjustment

Mechanical positioning of the vacuum guide is accomplished by a manual control located on the tape transport panel, see Fig. 7. This allows operators to manually compensate for variations in head-to-tape pressure which may occur in playback of

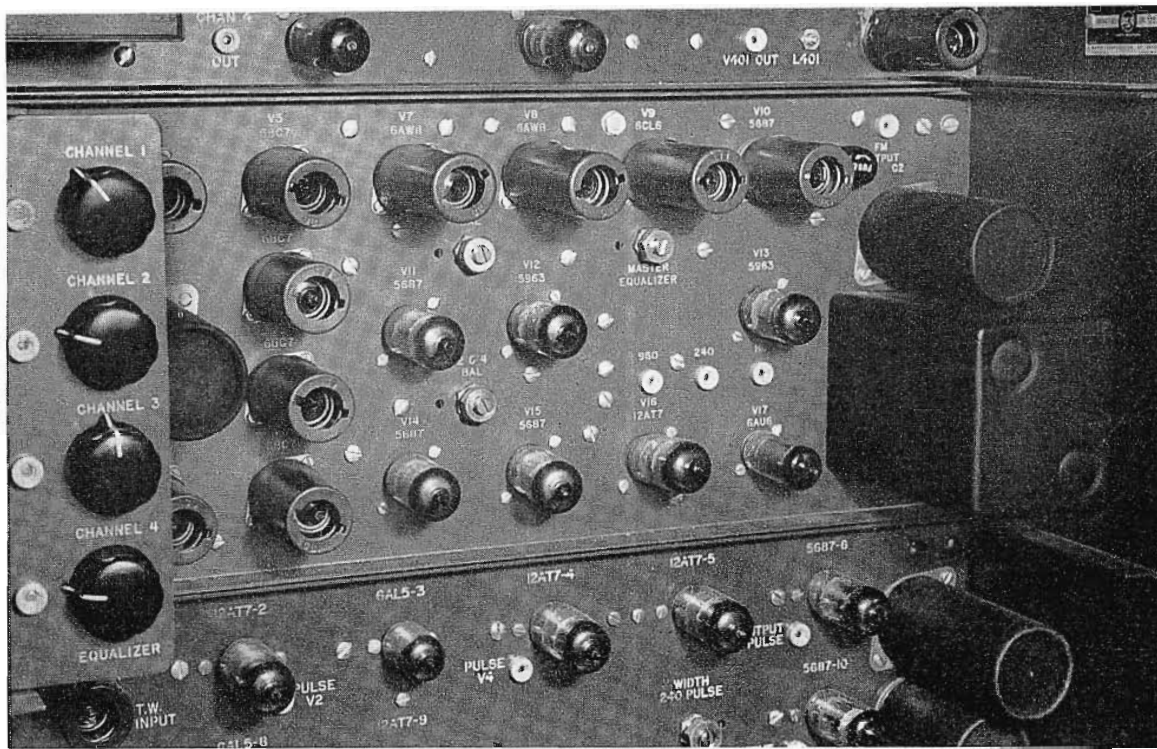


FIG. 4. This chassis incorporates the functions of both the 4 by 2 and 2 by 1 switchers found in the TR-11's senior partner, the TRT-1B TV Tape Recorder. In the re-design of this unit the sync separation function has been relegated to another chassis.

other tapes or as heads wear. This is a vernier type control providing precise setting of guide position. Once setup for a tape, it may be locked into position and stabilized until further adjustment becomes necessary.

#### Simplified Power Distribution

Because of the reduced power consumption in the TR-11 recorder, a single a-c power feed is supplied to one main connector, see Fig. 8. This simplifies power distribution and aids in reducing installation costs. The power distribution panel is built into the recorder. It is located at the rear of the control equipment rack and includes three a-c breakers to evenly distribute power throughout the equipment.

#### Accessories Aid Operational Convenience

A number of accessories can be added to the basic TR-11 recorder pictured in Fig. 1. These are designed to extend the

utility of the recorder and provide additional operational conveniences. Many of them can be mounted within the basic three-rack structure, and therefore will not add to the existing floor space.

To provide a convenient, compact master monitoring function at the recorder, a TM-35 monitor can be mounted in place of the blank panel adjacent to the control panel.

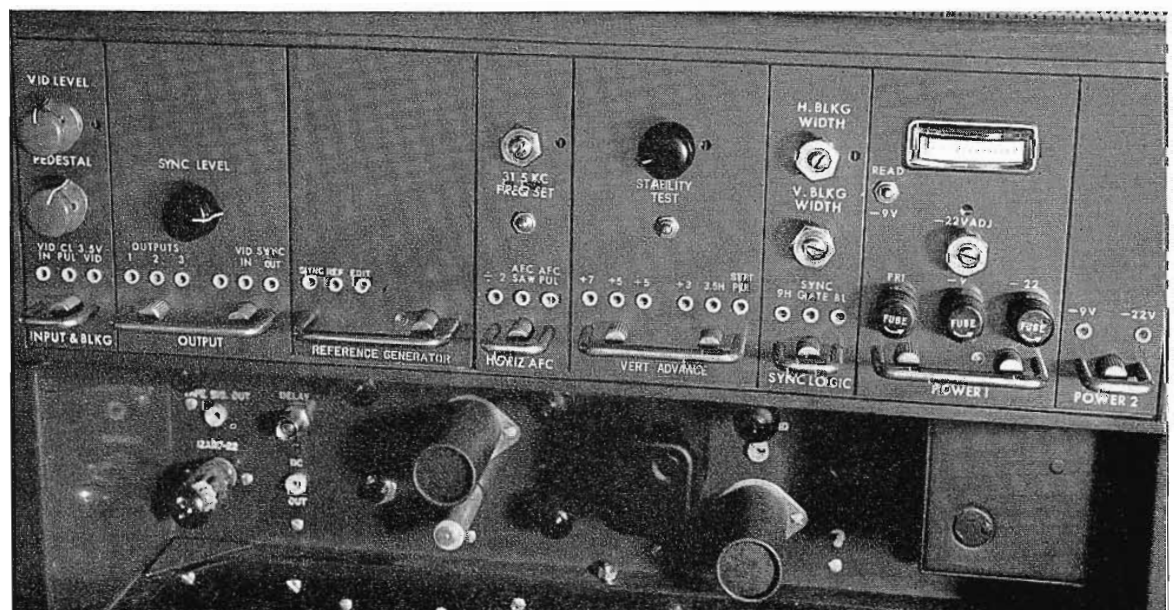
A master erase head may be installed in a position provided for it on the tape transport panel. Another position, just above the erase head, accepts an indicator lamp to show the presence of master erase current. Master erase is available in an easy-to-install kit form.

Remote control of the TR-11 can be accomplished by accessory remote control panels. One panel handles playback and record functions; also stop, fast-forward and fast-reverse controls. Another panel,

available separately, handles remote control of electrical functions—sync, pedestal and video. A remote control delegate switch is built into the TR-11 recorder.

A Pixlock accessory—which makes possible instantaneous roll-free switching as well as fades, dissolves, supers and special effects on tape—is also available. When using this accessory, the headwheel servo chassis supplied with the TR-11 may be removed and the transistorized Pixlock chassis installed in a portion of the space made available. The remainder of this space will be available to house an accessory automatic timing compensator, if desired. This equipment is also transistorized. It performs many of the manual electronic adjustments automatically—in effect, removing residual jitter, scalloping, skewing and quadrature errors in the TV tape playback signal.

FIG. 5. The sync separation function is contained in this transistorized reference generator module, third unit from the left in the processing amplifier. This module also provides reference and edit pulses.





Air bearing headwheel panels can also be used in the TR-11. These offer reduction in jitter, better picture quality and longer life. The headwheel panel itself can replace the panel supplied with the TR-11, however, the air pump must be mounted externally.

**Useful in Many Applications**

Many users will find both the compatibility and the low cost of the new TR-11 machine quite advantageous. This recorder can be used in conjunction with the TRT-1B recorder, since it is a compatible machine.

Educators will find the compatibility

feature very useful—tapes produced on this recorder can be reproduced on all standard quadraplex recorders. Furthermore, the owner of this RCA economy machine can utilize television tapes produced by quadraplex recorders. Thus tapes produced at ETV centers can be used.

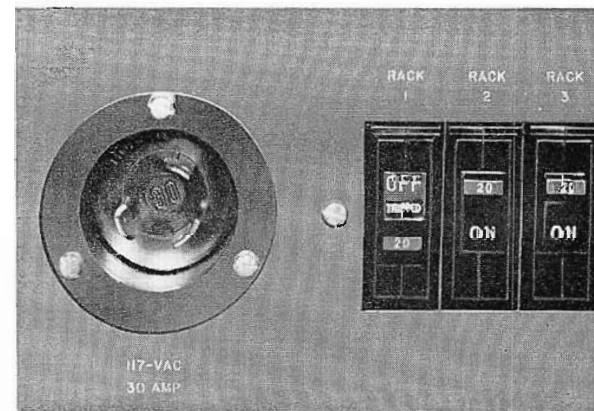
Program producers, agencies and broadcasters will find that this economy recorder opens new possibilities in production. Use of this recorder to record test shots, frequent takes, or pilots for previews does not tie-up the standard broadcast equipment. Moreover, anything recorded on the economy machine can be played on the larger equipment with "on-air" quality.

FIG. 6. Basic tape control functions are accommodated on this simplified control panel which also includes a monitoring switcher. In the panel adjacent to the control panel, space is available for mounting an accessory TM-35 Master Monitor which includes both picture and waveform presentations.

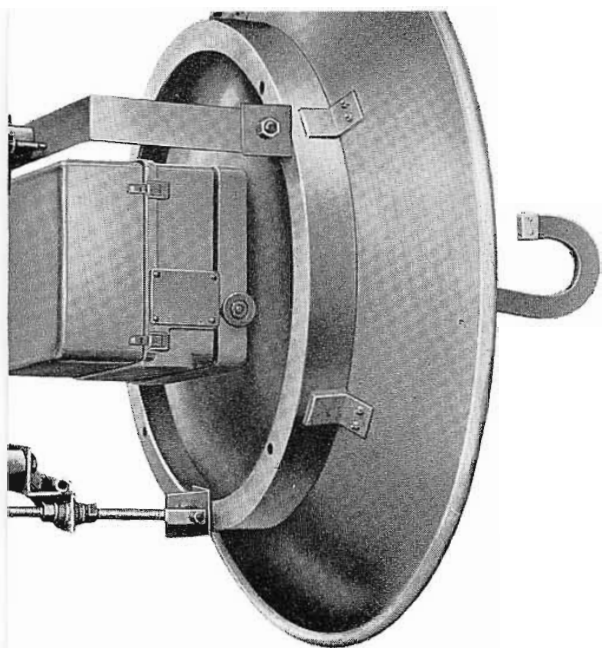


FIG. 7. This manual control mounted on the tape transport panel determines mechanical positioning of the vacuum guide. Thus, the operator can manually compensate for variations in head-to-tape pressure.

FIG. 8. Low power consumption in the TR-11 permits a single a-c power feed to be supplied to one main connector. Three a-c breakers evenly distribute power throughout the recorder.







# HOW TO ALIGN

by J. B. BULLOCK

*TV Microwave Engineering*

The growing number of privately owned TV microwave installations has focused attention on new techniques for proper installation and maintenance procedures. One of the most significant of these procedures, particularly in installation, is alignment of the antennas. Proper alignment is somewhat difficult because the radiated energy is concentrated in a very narrow angle, a pencil-like beam which is considerably more confined than the beam of light from an automobile headlamp. Furthermore, proper alignment requires accurate aiming of *both* transmitting and receiving antennas since both have equally narrow beam characteristics.

In many systems, passive reflectors are used to permit installation of the electronic equipment at ground level. These passive reflectors introduce added critical elements in the problem of alignment.

Successful initial alignment is not a guarantee of permanent maximum performance. When unusually high winds occur, or ice loads form, it is quite possible that antenna elements mounted on high towers can be shifted or deformed slightly with consequent loss in peak performance. It is, therefore, helpful to maintenance personnel that they be acquainted with effective techniques for checking and adjusting alignment when the need arises.

The most significant indicator of proper antenna alignment is measurement of the video noise level from the microwave receiver with the microwave system in operation. In practical terms this means measuring the signal-to-noise ratio at the output of the receiver. When the predicted signal-to-noise is realized, the full signal power for which the antenna system was designed will be delivered to the receiver.

## Standard Alignment Practice

The standard method of alignment is to install the antennas (or passive reflectors)

as close to previously calculated mounting angles as is possible and then to "fish" for one beam with the other until maximum signal is obtained. If this signal yields a signal-to-noise ratio within 2 db of that calculated value, then the antennas are considered to be aligned properly. This method is quite satisfactory with 4-foot (2.5 degrees beam at 7000 kmc) and with 6-foot (1.7 degrees beam at 7000 kmc) dishes, particularly over flat country with ample clearance provided.

## Problems of Alignment

Some of the problems encountered in antenna or passive reflector alignment are illustrated in Figs. 1 through 4. (Once a passive reflector is properly illuminated by its associated antenna, the method of its orientation is exactly the same as that of any antenna, providing the reflector is not swung out of the illumination.) The narrower the beam of the antenna, the more critical the alignment will be. As larger passive reflectors are used (in order to provide additional gain) the final beam directed along the path becomes narrower.

Typical starting orientation points are shown in Figs. 1 and 2. The difficulty of measuring dish or reflector angles usually prohibits making an initial set-up much closer than that shown. If a compass is used in the layout, precautions indicated in the section on "Alignment Procedure" should be taken. Azimuths are best obtained by using accurately located landmarks, or by celestial means.

If one of the antennas in Fig. 1 were oriented along the path, only a small signal would show up at the receiver. A stronger signal might be found when moving one antenna only, if the beam should come upon a good reflecting surface already in the path of the other beam (see Fig. 3).

Figure 2 again illustrates that if *only one* reflector is oriented at a time, there will be no strong indication to show when it lies properly along the path. Also, in both Figs. 1 and 2 the antenna patterns shown are further complicated by the existence of minor lobes which can lead to further false orientations (see Fig. 4).

## Alignment Procedure

Proper orientation requires carefully planned movement of both antennas (or reflectors). To find the proper orientation simply by panning, *both* ends of a system must be panned *simultaneously*, and in the panning, the beams must be passed "through" each other, see Fig. 5.

The proper starting point is with both beams horizontal and in the nearest possible "on path" orientation that can be determined from the means at hand. Surveying and driving marker stakes relative to known landmarks is probably the best beginning. In the absence of accurate landmarks, azimuth can be obtained from the stars, or approximate directions may be obtained from a compass. If a compass is used, precautions must be taken to reduce inherent errors, i.e., magnetic declination, proximity to metal objects, etc.

A stake driven along the line of the path, several hundred feet from the lower base, will permit "aiming" an antenna or reflector in the desired direction. This is done by setting a transit up over the stake and sighting back at the reflector. When top and bottom edges of the reflector are parallel to the horizontal cross hair of the telescope, the reflector is "aimed" along the line toward the stake. In the case of an antenna, the plane of its feed horn may be compared with the cross hairs in the telescope.

From this starting point, the antenna at one end of the path should be moved in azimuth to a maximum signal indication. This generally assures that if the beams are off, they will be off on the same side of the path (such as shown in Fig. 3). Simultaneously the antenna at one end of the path is panned right-to-left, while the antenna at the other end is panned left-to-right. In this manner the beams will pass through each other as shown in Fig. 5.

The panning procedure will often require that the location of a "maximum" be abandoned by *both* ends (note Figs. 3 and 4). The location of a maximum should always be noted, however, since it may be significant for *one* end, as in Fig. 4.



# MICROWAVE ANTENNAS

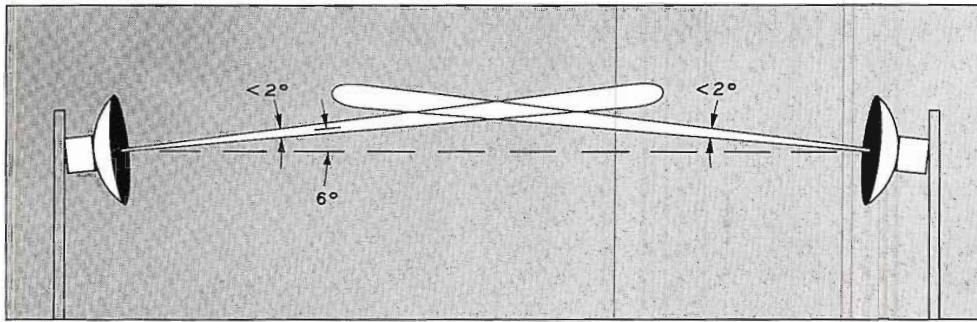
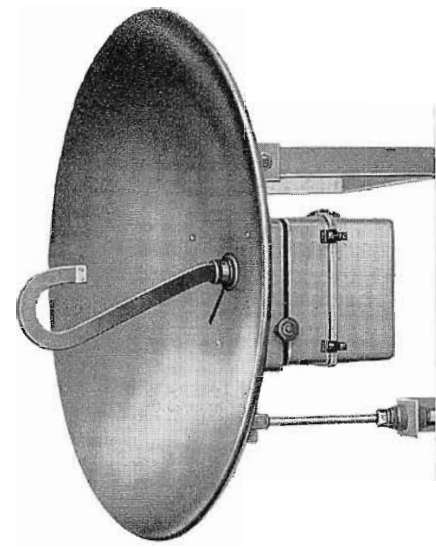


FIG. 1. Antennas less than 6 degrees off path, yet virtually no signal is obtained at receiver.

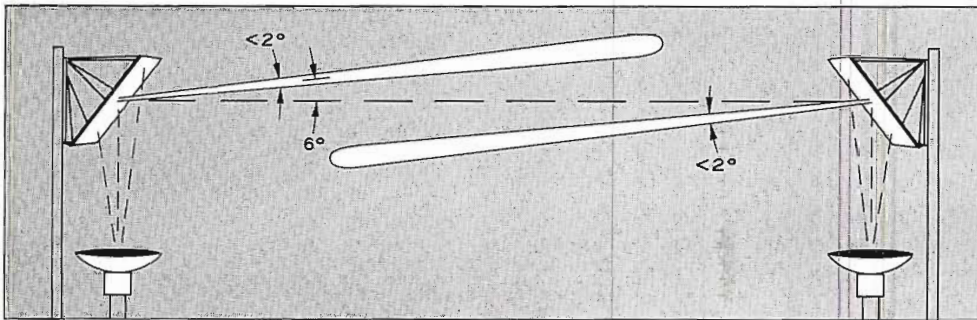


FIG. 2. Reflectors less than 6 degrees off path, yet virtually no signal is obtained at receiver. The same thing can happen in azimuth as is shown here in elevation.

FIG. 3. Antennas approximately 20 degrees off path, yet reflection yields greater signal at receiver than was received in either Fig. 1 or Fig. 2. If either antenna "alone" is oriented along path, signal received will be weaker than reflection shown.

When a promising signal has been maximized in azimuth, it should be explored in elevation using the same technique as used in panning horizontally. With antennas alone the true maximum will generally be with the dish face vertical. With reflectors which are directly above their antennas, the maximum will generally be when the reflector face is at 45 degrees with the vertical. This is because the difference in antenna (or reflector) absolute elevations is likely to be very small compared to the path length. In the case of the reflector, the 45-degree angle will change if its antenna is not located directly below it and on the path line. The new angle will be difficult to calculate only if the antenna is off the line of the path. In panning vertically, the most prominent false maxima will be ground reflections, and they will be *below* the true maximum in elevation angle.

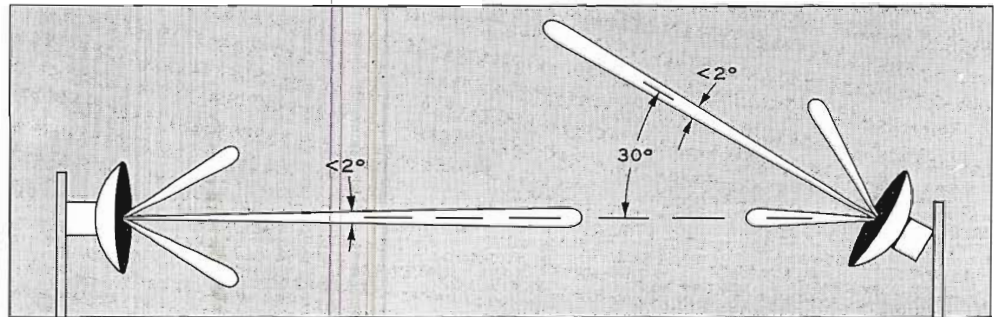
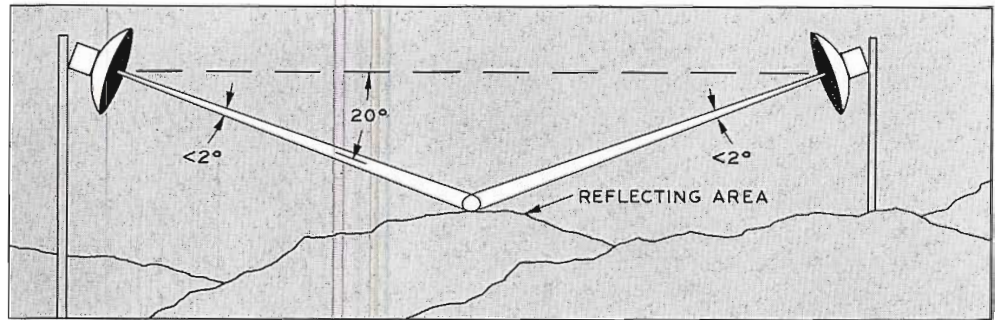


FIG. 4. Major lobe of one antenna and minor lobe of other nearly on path. Receiver signal strength is comparable to that of Fig. 3. Minor lobes in sketch are exaggerated.

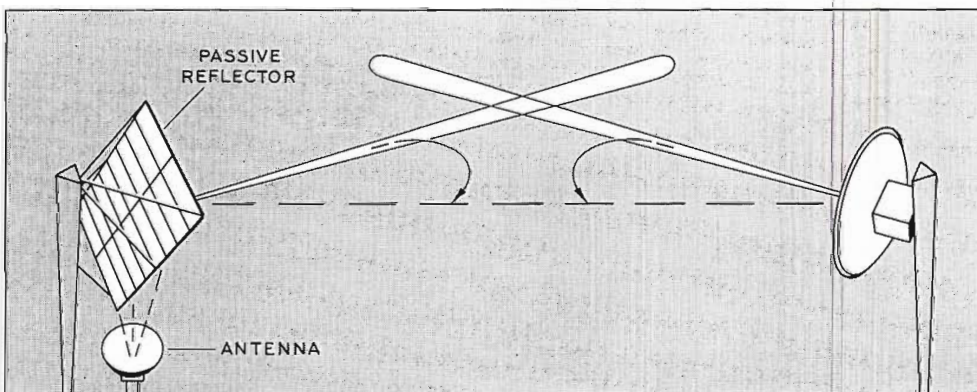


FIG. 5. To find maximum signal, beams must be panned "through" each other. Here beams from a passive reflector and antenna are off path in azimuth,

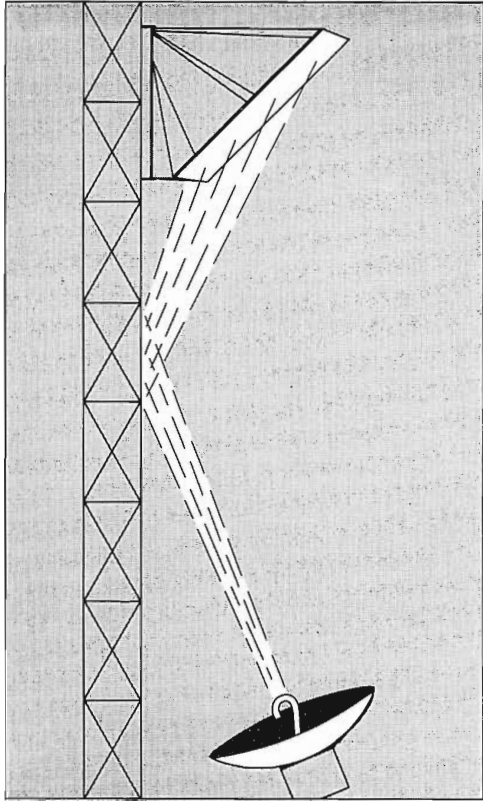


FIG. 6. Reflector illuminated by tower reflection. This is to be avoided.

#### Passive Reflector Illumination and Curvature Adjustment

Many passive reflectors have a bowing, or curvature adjustment on them. It is recommended that this adjustment be left such that the reflector face is flat until the proper antenna maximum (as verified by signal-to-noise measurement) has been found. This avoids unpredicted distortion of the antenna pattern caused by too much face curvature. Curvature adjustment may then be made to yield one or two db more signal strength.

A passive reflector must be properly illuminated by its companion antenna if the combination is to yield the predicted gain. An error in reflector illumination which is likely to occur on tall towers is illustrated in Fig. 6. It is evidenced by widely fluctuating received signals when a man climbs through the illuminated portion of the tower. A nominal 8 to 12 db reduction in predicted receiver signal-to-noise can be expected. Reflections off the surface of other objects (large warehouses, etc.) may also be verified by noting the effect of motion in front of the suspected surface on the received signals.

It is usually possible to optically sight an antenna so that it will very nearly illuminate its reflector properly. One method is to replace the button-hook antenna feed by a straight length of waveguide and sight through the waveguide. Another method is to attach a long straight edge

along the buttonhook, taped to it at the base and at the mouth. It is then possible to sight from various angles on the ground and determine where the dish is pointing.

Before making a signal-to-noise measurement, the illumination of each reflector should be checked by panning its antenna in two planes for maximum signal at the microwave receiver. Do not move the *location* of the antenna, only its orientation.

#### Polarization

Antenna polarization must be the same at both ends of a link, if a full received signal is to be achieved. This should always be checked prior to a S/N measurement. It is done by rotating the antenna assembly or just the antenna feed at *either* end of the link. As a practical matter, almost no change in signal will be noted unless polarization is off by more than 20 degrees. Where passive reflectors are used, additional polarization rotation is encountered if either antenna is off the path line between reflectors. When polarization is rotated, beam orientation may shift slightly and thus require some touch-up.

#### Orientation by Substitution of Low Gain Horn

Earlier it was indicated that the difficulty in antenna orientation stems from the narrow beams involved. Where physical arrangement of reflectors to be oriented permit its use, the following method will remove this obstacle, and make it possible to pan one end of a link at a time. The

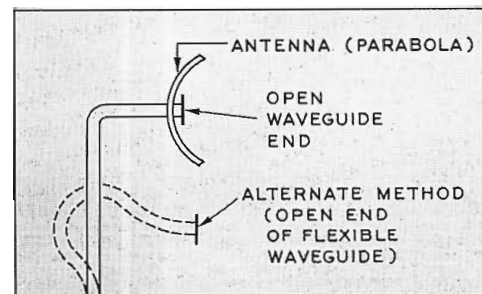


FIG. 7A. Horn located at parabolic antenna site.

procedure is presented in step by step form, assuming that the antennas or reflectors have been mounted, properly illuminated, and set as near to proper orientation as possible by optical means (about  $\pm 10$  degrees).

1. Replace the antenna at one end of the path by a low gain horn. The open end of a piece of waveguide will be an adequate "horn". On a dish to dish path, this can be done by merely removing the antenna feed and leaving the dish undisturbed. This may be performed at either end of the path, see Fig. 7A.

In another method, open waveguide may look out on the path under or over the parabola. Check polarization.

At a location involving a passive reflector, the horn must be oriented so that it radiates along the *path* with proper polarization, *bypassing* the passive reflector. Exact azimuth and elevation orientation is not critical due to the broad pattern of the "horn". The horn should be located high enough to give 0.6 Fresnel zone clearance over a 4/3 earth to avoid obstruction losses.

This generally means that the "horn" must be mounted part way up on the tower, but probably not as high as the passive reflector itself. Figures 7B and 7C illustrate two possible ways of locating the "horn". In the method of 7B, the horn is fastened to a convenient point on the tower and fed from the transmitter below via waveguide or coax line. This method is difficult to accomplish in practice if much line length is involved (because of losses if coax is used, and because of unwieldiness and expense if waveguide is used).

If line length makes the method of 7B impractical, then 7C is the preferred alternate. Here the transmitter (or receiver) chassis itself is taken up the tower and fastened so that it looks out on the path. The transmitter output opening itself may then serve as the "horn" directly, or a short length of flexible waveguide may be used. The latter may be employed to facilitate orienting and by-passing obstructions (such as tower legs, etc.). Standard camera cable is run up to the transmitter from its control unit, and for this purpose there is almost no limit to the length that can be used.

Once the "horn" has been mounted, the orientation situation will generally be like that indicated in Fig. 8.

2. The high-gain antenna end of the system should now be oriented in azimuth and elevation for maximum signal. The signal-to-noise at the receiver output may be noted, and should come within about 4 db of the value calculated (unless clearance is not adequate, or the "horn" orientation is radically off). The calculated signal-to-noise is determined in the usual manner,<sup>1</sup> using 10 db for the gain of the open waveguide end (the "horn") in place of that of the standard antenna (usually about 40 db). Thus a signal-to-noise ratio about 30 db below the final should be expected. Although noisy, it will be readily

<sup>1</sup> Information on the calculation of expected S/N ratios for TVM-1A and 1B equipment may be found in any of the several editions of the equipment instruction books, 1B-36757.



discernible. (A measurement is usually *not* necessary since generally only *one* maximum will be found).

Initial panning may require watching the receiver's video output on a CRO instead of observing the signal level meter. A weak signal may sometimes be observed in the noise before it produces sufficient AGC to register on the meter.

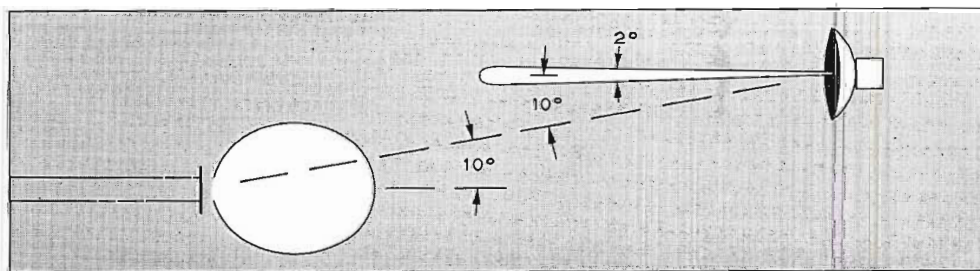
If a passive reflector is being bypassed, as in the connections indicated by Fig. 7B, then the losses in the transmission line will further decrease the signal-to-noise obtained. If the transmission line loss is 5 db, then the signal-to-noise expected would be reduced by 5 db. An obstruction loss of 5 db due to inadequate clearance would have a similar effect, but would vary with time and weather changes.

Transmission line loss or inadequate clearance losses will render this alignment technique useless if they amount to much over 10 db.

Comparison of Fig. 8 with Figs. 1 through 4 shows the advantage of this method in readily detecting "on path" orientation of the sharp beam since

- a. When the high gain antenna is panned through the path line, it receives near maximum signal unless the "horn" is off path line by many degrees. Such inaccuracy is unlikely.
  - b. If a signal reflected from something in the beam of the horn is encountered in panning the sharp beam, this reflection signal will be reduced by loss; and thus barely noticeable.
3. Remove the "horn" and reconnect the high gain antenna at the horn location. Orient this high gain antenna for maxi-

FIG. 8. Possible initial positions of horn and high gain antenna prior to orientation.



imum signal in azimuth and elevation. This should place it also in the "on path" position.

4. Both antennas should now be "on path". Check polarization and measure the signal-to-noise at the receiver end of the link. It should be within 2 db of calculated. If passive reflector move-

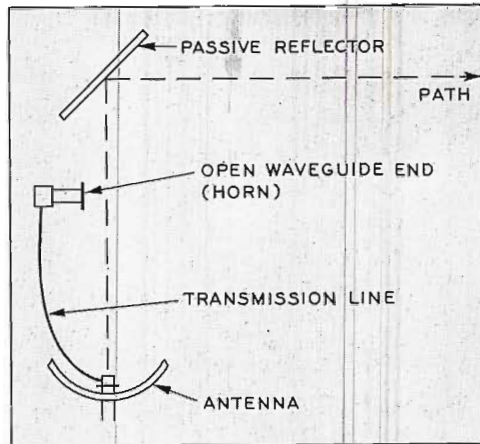


FIG. 7B. Horn located at passive reflector site.

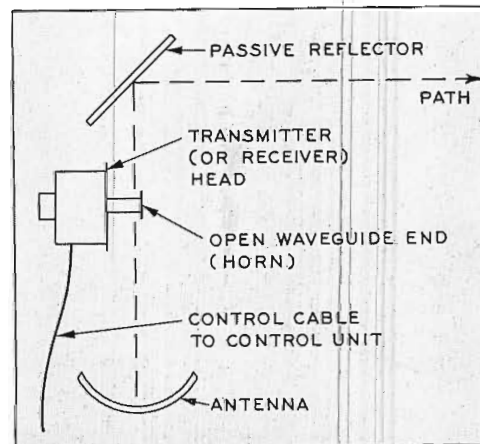


FIG. 7C. Horn located at passive reflector site.

ment was involved and was greater than a few degrees, it may be advisable to recheck the reflector illumination.

### Signal-to-Noise Measurement

The achievement of a predicted S/N ratio over a microwave link depends on several other factors including:

Proper transmitter power output, proper

1. Turn off sound diplexing equipment; also turn off any standby transmitters or receivers.
2. Disconnect any video input from the transmitter, and terminate the VID INPUT jack.
3. Switch transmitter modulation to the TEST 1 position. This sets transmitter deviation at 6.0 mc p/p. It may be advisable to check this. Remove restoration network if any from the receiver.
4. Set the receiver OUTPUT LEVEL control to give 1.5 V p/p<sup>2</sup> signal, measured on a CRO across a terminated output.
5. Switch the transmitter MOD SELECTOR switch to PIX.
6. Measure noise level at receiver output. Use either a wideband (10 mc) CRO or an average responding wideband VTVM, calibrated in rms of a sine wave. (This meter is nominally down 3 db at 8 mc).

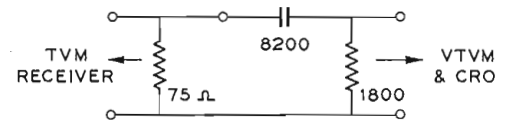


FIG. 9. Arrangement for measuring random noise showing R-C filter connection for blocking hum from measurement.

Connect CRO across receiver output to verify that "noise" being measured is purely random.

- a. If the CRO is used for measuring, it is best set for 60 cycle sweep, with the sweep collapsed to about 1/4 inch width. The p/p amplitude of noise may then be read and p/p to p/p S/N in db calculated from

$$S/N = 20 \log \frac{1.5}{\text{p/p noise volts}}$$

- b. If the VTVM is used, its scale may be read directly and the p/p to rms S/N in db calculated from

$$S/N = 20 \log \frac{1.5}{\text{rms noise volts}}$$

The (b) method of measurement yields a number which will be a nominal 20 db larger than the method in (a). This is because the rms value of a given noise level is less than its p/p value and the VTVM bandwidth is less than that of the CRO. The 20 db figure may be used as a conversion factor between the two methods.

If, in either measurement any significant amount of hum is observable, then the noise measurement should be made through a filter which will eliminate the hum, see Fig. 9. The filter is removed when measuring signal amplitude.

<sup>2</sup> A 1.0 volt level may be used if desired.

# NEW 20-KW FM TRANSMITTER

Combination of Two 10-KW

Amplifiers Produces Double  
Reliability While Maintaining  
Full Fidelity Operation

by I. H. LUBASH

*Broadcasting Transmitter Merchandising*



FIG. 1. The type BTF-20 is a compact three-cabinet 20-kw transmitter. It employs the RCA "Direct FM" exciter, which gives widest frequency response with minimum distortion.

The BTF-20D is the newest in RCA's growing line of FM broadcast transmitters. It incorporates solid-state power supplies, full overload protection, and built-in remote control. Like all previous RCA transmitters, it employs the performance proven direct FM system. This keeps distortion down to a minimum, makes it easy to tune and to maintain high performance.

The BTF-20D Transmitter consists of two 10-kw amplifiers driven by a common driver and exciter. The signal is combined in a diplexer and then fed to the antenna. Each 10-kw amplifier is completely independent of the other, and both are identical in construction. This makes maintenance easier, and gives the assurance of built-in standby protection should failure occur in one of the amplifiers.

## Compact High Power

The three cabinets of the BTF-20D fit into an area 32 by 104 inches. The center cabinet contains the famous "Direct FM" exciter, BTE-10B; 400 watt driver; control and switching circuitry; and dividing

FIG. 2. Two identical 10-kw amplifiers are housed in cabinets at either end of the transmitter. Center cabinet contains "Direct FM" exciter and 400-watt driver.





system to feed the power amplifiers. On either side of the center cabinet is a 10-kw power amplifier. Two external high voltage transformers can be placed in any convenient location. The two power amplifiers are driven in parallel and the outputs are combined to deliver a full 20-kw of power to feed the antenna. With the BFA series of FM antennas, up to 240-kw ERP can be obtained from the BTF-20D.

Only twenty-one tubes (13 types) are used in the BTF-20D. Eighteen tubes (11 types) are used in the exciter, and from the output of the exciter only three tubes in single ended circuits (a ceramic 4CX300A in the IPA and a ceramic 4CX5000A in each PA) are required to produce a 20-kw signal. In any emergency, the BTF-20D can operate with a multiplexed 20-kw output with as few as ten tubes.

### Emergency Provisions

Depending upon the selection of optional transmission line switching equipment, it is possible to reduce transmitter power to as low as 1 kw, or even to do maintenance on one power amplifier while the other remains on the air. Standard equipment on the BTF-20D is a power combining diplexer and a reject load rated at 1.5 kw. If there should be an imbalance or failure of one PA, the power in the reject load will go above 1.5 kw, an alarm is sounded, and the transmitter is automatically taken off the air. By addition of optional transmission line switching, it is possible to switch the still-operating power amplifier directly into the antenna feed line to stay on the air at reduced power. This switching can be provided for manual or electrical change over.

### Extra Protection

If desired a 7.5 kw reject load can be installed in place of the 1.5 kw load. Thus, even if one PA should fail, the transmitter can stay on the air and programming will not be interrupted though output power will drop to 25 per cent.

The transmitter has been designed for balanced input to each power amplifier from the driver. This is accomplished by tuning the input matching meter for minimum reading at each 10 kw amplifier.

Each power amplifier has its own reflectometer for reading output power and VSWR; in addition there is another reflectometer at the output of the combining diplexer measuring power fed to the antenna. Twenty kilowatts are easily provided at this point.

Each of the three cabinets contains its own separate blower for maximum cooling. The plate power to the driver stage is

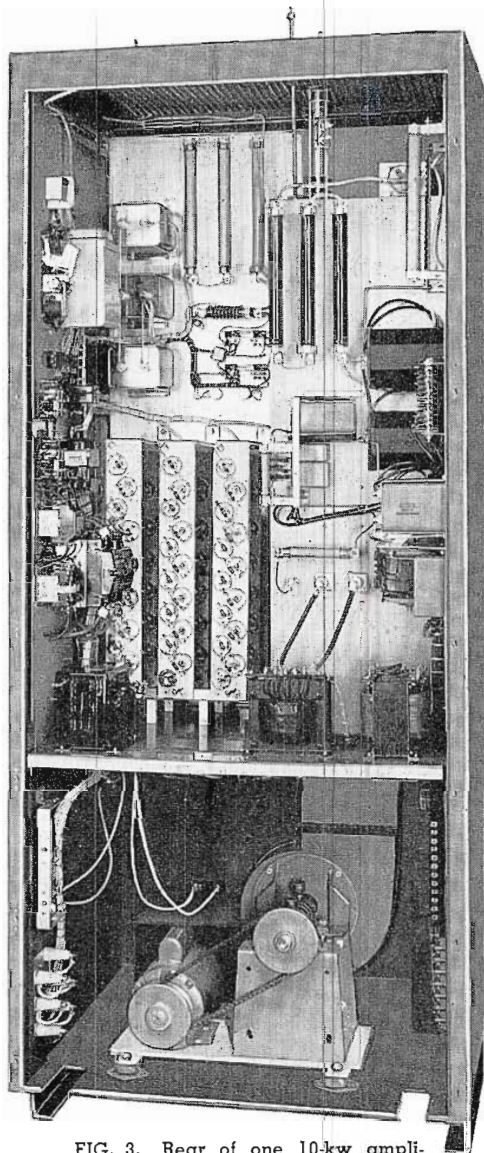


FIG. 3. Rear of one 10-kw amplifier. Note blower at bottom. Each PA has its own plate transformer and grid bias supply.

supplied by the "dominant" power amplifier. If the "dominant" power amplifier should fail, driver plate power is automatically obtained from the other power amplifier remaining on the air.

The power amplifiers are identical even to the external high voltage transformers. This duplication, since there is a constant reference, makes servicing and trouble shooting quicker and easier. By comparing meter readings and by visual comparison, faults can be corrected in much less time than would otherwise be normal.

The IPA uses a ceramic 4CX300A to produce 400 watt output to drive the two power amplifiers. The IPA stage is very similar to the one used in the BTF-10C FM transmitter.<sup>1</sup> The 4CX300A IPA stage has conventional pi-networks with variable capacitors in the input and output stages.

<sup>1</sup> New 10 kw FM Transmitter, *Broadcast News*, Vol. No. 107, March 1960.

The variable capacitors act as the matching components, and tuning from 88-108 mcs. is accomplished by varying the inductances in the pi-networks.

Plate voltage for the IPA is obtained from the center tap of the power supply of the "dominant" PA. The "dominant" PA and the IPA screen voltages work together. If the "dominant" amplifier should fail, automatic switching takes place so that the IPA power is obtained from the second PA. The IPA is protected by the overload relays in the cathode circuit. Air interlocks are provided to remove plate and screen voltages if the cooling air flow should stop.

### Proven Design

Each power amplifier is essentially the same as the proven power amplifier in the RCA Transmitter, BTF-10C.<sup>2</sup> The primary advance is that efficient, long life silicon diodes have replaced tube rectifiers. Each power amplifier uses the rugged 4CX5000A which is capable of putting out 10 kw of power.

### Easy To Tune

The input of each PA is a modified pi-network in which the input capacity of the tube is shunted by an inductive line to reduce the effective input capacity of the stage. This inductance is also used to vary input loading. A capacity in parallel with the coil varies the inductive component of the circuit. Each PA also incorporates its own separate grid bias supply for additional stability.

Plate loading and tuning are achieved by variation of two inductive line components in a pi-network arrangement. Tube capacity is shunted by the variable inductor. The pi-network has been inverted for mechanical simplicity which results in grounding one end of the inductance, and eliminates the problem of insulating the variable component from ground. However, the output line must be in parallel with the inductance to bring it to ground potential. This is done by extending the output line down one side of the inductive line.

Initial tuning is done by approximate setting of all variable components according to a tuning curve. Final tuning is accomplished under reduced plate and screen voltage for circuit protection. The PA stage is neutralized by variation of the inductance in series with the screen supply. Tuning across the 88 to 108 mc FM band requires the changing of only one frequency determining part in each PA input circuit.

<sup>2</sup> Ibid.

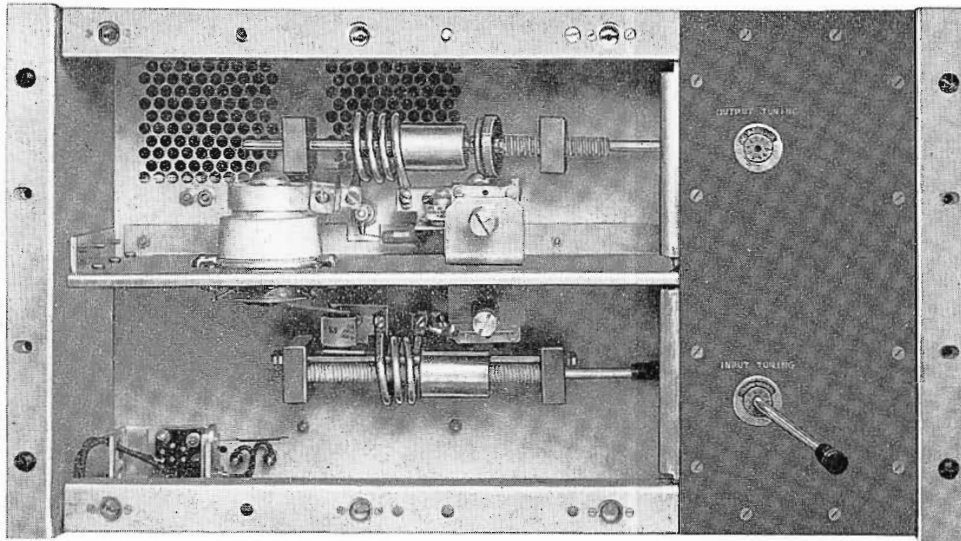


FIG. 4. This 400-watt IPA stage is used to drive the two 10-kw Amplifiers. Note tuning controls at right: upper is output tuning, lower is input tuning.

### Special Filter

Each power amplifier feeds into a reflective type harmonic filter which is not merely a second harmonic trap. No power is absorbed in this filter which consists of an M-derived half-T section, several low pass filter sections, and a constant K, half-T section. Use of this RCA filter assures compliance with FCC requirements for spurious radiation. All harmonic through the seventh are effectively attenuated. The output of the two harmonic filters is then combined in a broadband diplexer. All output connections will match  $3\frac{1}{8}$ -inch transmission line. Total output power is determined after this point.

### Semiconductor Power Supplies

No tube rectifiers are used in the BTF-20D transmitter. Semiconductor power supplies have been standard in the "Direct FM" exciter, BTE-10B, since it was first introduced a number of years ago. Each power amplifier in the BTF-20D has six banks of heavy duty silicon diodes.

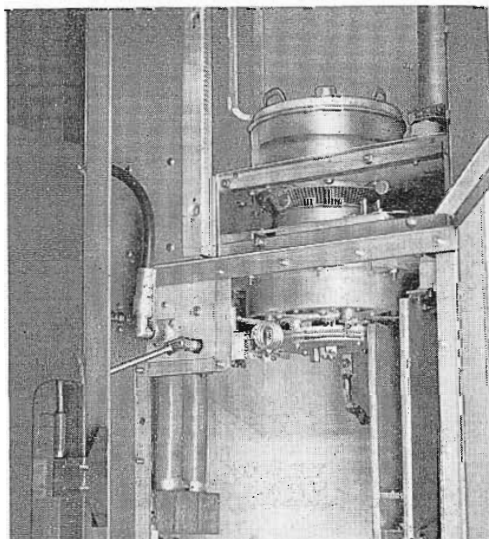


FIG. 5. Ten-kw power amplifier stage.

As a result, the BTF-20D has an extremely wide operating temperature range,  $-20^{\circ}$  to  $+45^{\circ}\text{C}$ . This savings in heating requirements can be reflected in the construction and maintenance of the transmitter building, particularly if the transmitter is to be remote controlled.

### Full Overload Protection

The only fuses used in this transmitter are in the crystal oven heater circuits. Magnetically tripped circuit breakers and overload relays are used throughout for better protection. Time delay relays are used so that plate voltage cannot be applied to the power amplifier tubes until the filaments have properly heated. Each amplifier is designed to automatically come back on twice after brief overloads. After the third overload, the transmitter will stay off. This one feature will materially reduce off air time due to momentary overloads or brief failures in power fed to the transmitter.

### Built-In Remote Control

The BTF-20D is designed for remote control; no extra motor control or metering equipment is required. Terminals are provided for remote control of transmitter on/off, plate on/off, raise/lower power, overload reset, etc. Remote metering connections for each PA are supplied as follows: cathode current, plate current, and power output. All RCA broadcast transmitters are designed to operate with the BTR-11B or BTR-20A remote control systems. This control equipment requires only two low cost DC telephone lines (one each for control and metering) with a maximum resistance of 5,000 ohms per line. RCA remote control does not use tones for control but instead uses the principle of a switchable momentary contact.

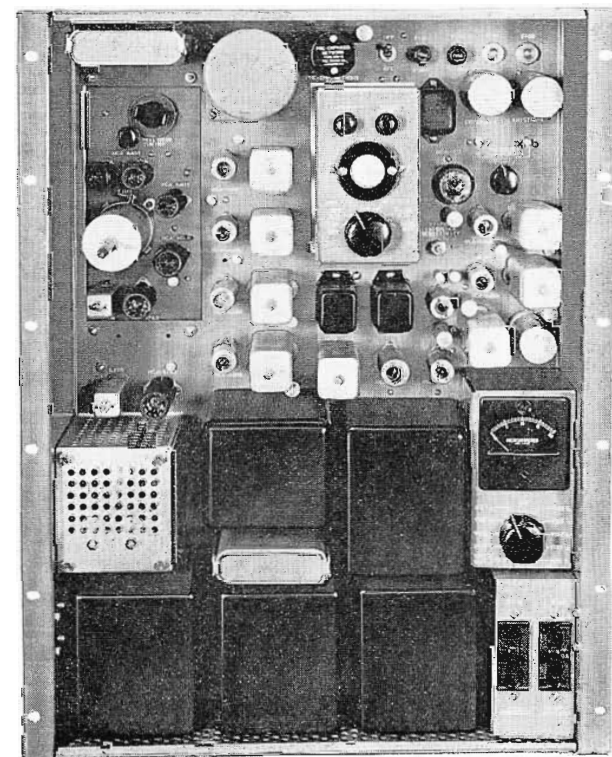
### Direct FM System

The heart of the BTF-20D is the time-proven "Direct FM" exciter, BTE-10B.<sup>3</sup> With this exciter, RCA FM transmitters supply the widest frequency response with minimum distortion. Frequency response for all RCA FM transmitters, including the BTF-20D, is from 30 to 15,000 cycles  $\pm 1$  db. Harmonic distortion over the same range and harmonics to 30 kc is 0.5 per cent or less. Consequently, RCA FM transmitters have the finest sound.

The "Direct FM" oscillator operates at  $\frac{1}{18}$  carrier frequency (5-6 mc). There are only *three* frequency multipliers in the circuit, thereby keeping distortion to an absolute minimum. The only tubes that have any effect on the quality of the signal are the seven in the modulator, oscillator, sub-carrier input, and frequency multiplier circuits. The remainder of the tubes in the exciter are in the AFC and "off-frequency" circuits. In the event of a failure in the latter circuits, they can be switched off and the carrier kept on the air with manual frequency control.

The BTE-10B is easy to tune and maintain. All circuits in the "Direct FM" exciter are single tuned to reduce the number of tuning adjustments. The RCA exciter <sup>3</sup>New FM Transmitters & Multiplex Equipment, *Broadcast News*, Vol. No. 102, Oct., 1958.

FIG. 6. Type BTE-10B Exciter including self-contained semiconductor d-c power supply is housed on hinged vertical chassis which provides instant accessibility to all components and circuits. The built-in scope permits constant observation of the AFC circuits. The meter is used to check all important circuit constants.





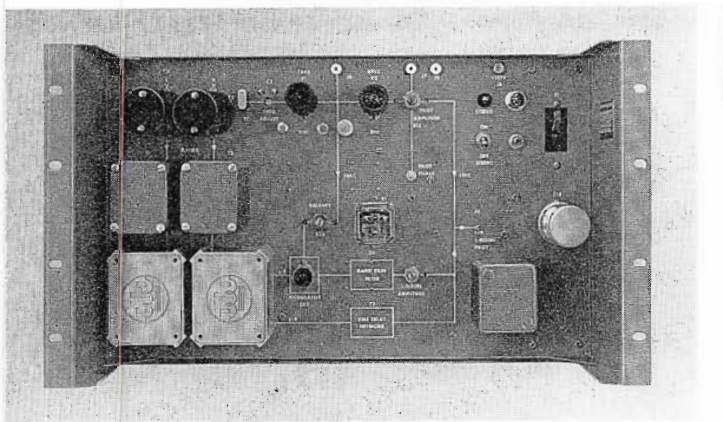


FIG. 7. Stereo Subcarrier Generator, Type BTS-1A—an optional accessory for FM stereo operation.

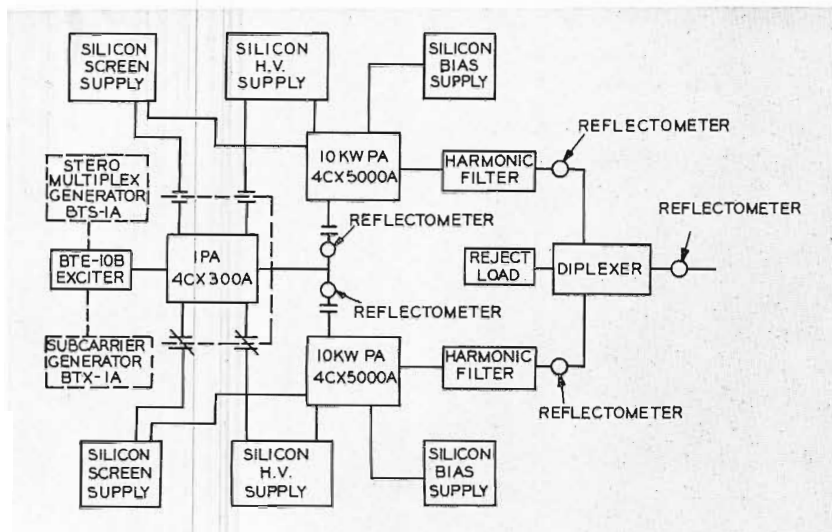


FIG. 9. Block diagram of BTF-20D Transmitter.

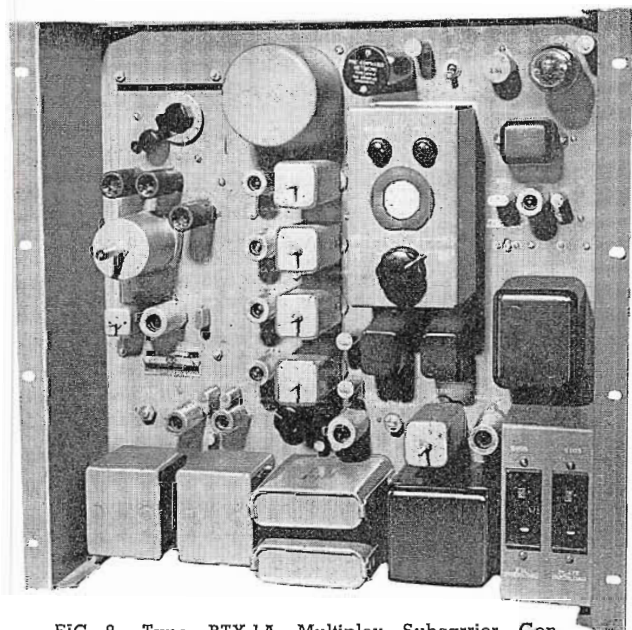


FIG. 8. Type BTX-1A Multiplex Subcarrier Generator—an optional accessory for multiple operation.

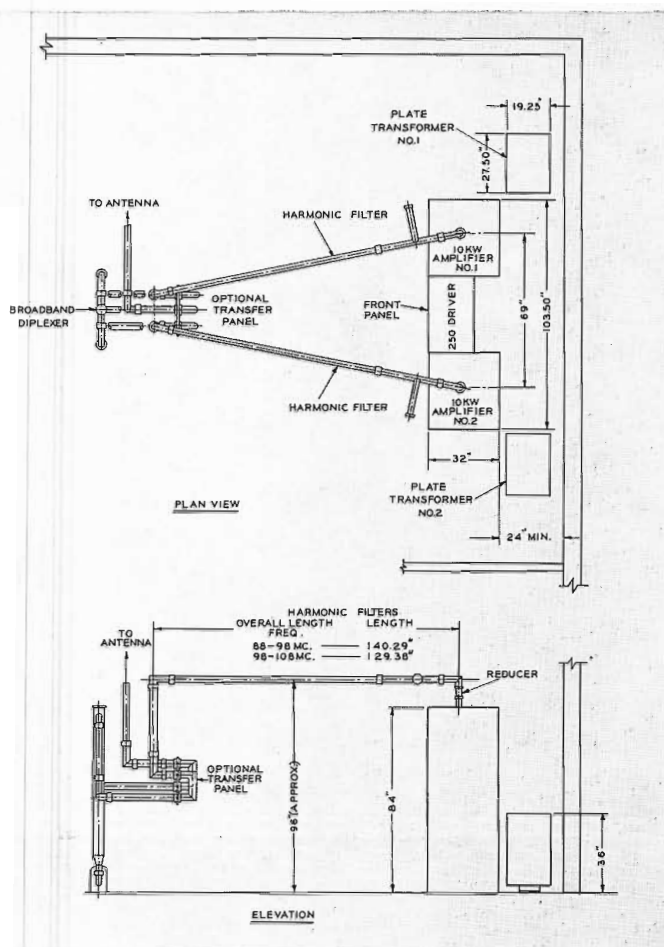


FIG. 10. Typical floor plan for BTF-20D.

has a built-in multimeter and oscilloscope to simplify tuning, trouble shooting, and maintenance.

An "off-frequency detector" automatically removes plate power from final amplifiers, preventing the transmitter from operating beyond frequency limits. Actually the "off-frequency detector" is a phase detector that compares the reactance modulator with a constant crystal source. As a result, "Direct FM" frequency stability is determined by the reference crystal oscillator.

### Multi-Channel Operation

The BTF-20D has been designed and proven for stereo and SCA operation. The RCA stereo subcarrier generator, BTS-1A, can be used with the BTF-20D for FM stereo operation. In addition to stereo, an SCA channel can be operated simultaneously by adding the RCA BTX-1A subcarrier (SCA) generator and an MI-560003 filter. If the station does not broadcast stereo, two SCA channels can be transmitted simultaneously.

The subcarrier generators along with

other associated equipment can be placed in an optional accessory equipment rack designed to harmonize with the appearance of the BTF-20D. The accessory equipment rack can be placed on either side of the transmitter. The rack is complete with full front and back hinged doors.

Operating with RCA's new broadband antennas,<sup>4</sup> the BTF-20D can provide effective radiated power up to 240 kw.

<sup>4</sup> New Broadband FM Antennas, *Broadcast News*, Vol. No. 101, August 1958.





In the current 1961-62 television season NBC color programming continues to show a marked increase over last season. Not only the total of color hours has increased, but also the number of types of shows. And the number of sponsors shows a spectacular climb. Moreover, considerable effort has been expended to maintain a good balance in color programming throughout the day. This is important to advertisers and stations, as well as set owners.

#### Daytime Color

The daytime color schedule starts out in early morning with CONTINENTAL CLASSROOM, followed by a series of top-rated shows, Monday through Friday, each headed by a top personality:

- PLAY YOUR HUNCH  
10:30-11:00, with Merv Griffin
- PRICE IS RIGHT  
11:00-11:30, with Bill Cullen
- IT COULD BE YOU  
12:30-12:55, with Bill Leyden
- CHARGE ACCOUNT  
2:00-2:30, with Jan Murray

On Saturday morning, three additional programs are being presented in color:

- PIP THE PIPER—9:30-10:00
- SHARI LEWIS—10:00-10:30
- KING LEONARDO—10:30-11:00

An afternoon addition, which premiered on September 17, is PATTERNS IN MUSIC. Originating in Chicago from WNBQ, the program is an unusual treatment of big orchestra sounds featuring intriguing and inventive musical effects supplementing the music.

Daytime color total really paid off for 1961. The number of hours in 1960 totalled

Late evening viewing is represented by JACK PAAR. He continues every weekday night—Monday through Friday.

On Sundays, 6 to 6:30, is MEET THE PRESS, TV's foremost press conference.

The Cartright family is on Sundays, 9 to 10. (Of course, color is the prime reason Chevrolet selected BONANZA for

## NBC COLOR PROGRAMMING CONTINUES TO INCREASE

558; in 1961, this figure reached 815 hours. (This is triple the figure in 1959.)

#### Nighttime Color

Dynamic growth is equally evident in the yearly totals for nighttime. From 476 hours in 1960 to 815 in 1961—an increase of over 70 per cent.

this time slot. It's consistently the "best-liked" western.)

Bill Cullen is seen Monday nights to play THE PRICE IS RIGHT.

In his familiar time period—9 to 10 on Wednesday—is Mr. Relaxation himself, PERRY COMO.



FIG. 1. "Disney's Wonderful World of Color," Sundays, 7:30 p.m.

FIG. 2. One of three new color programs, Saturdays, 9:30 a.m.

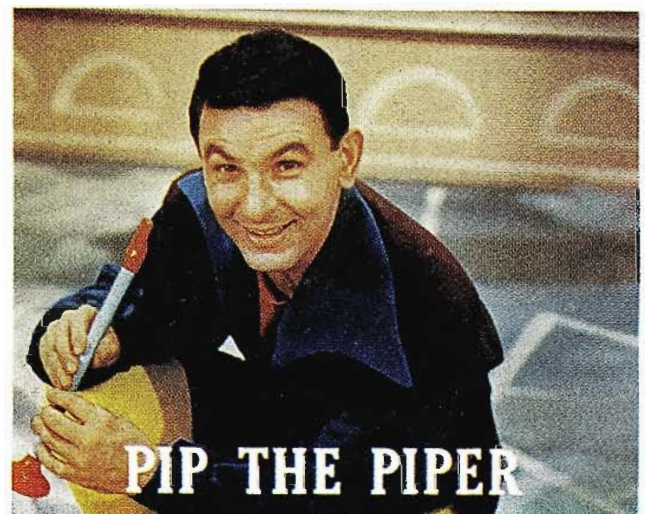




FIG. 3. Color news column, Wednesdays at 10:30 p.m.

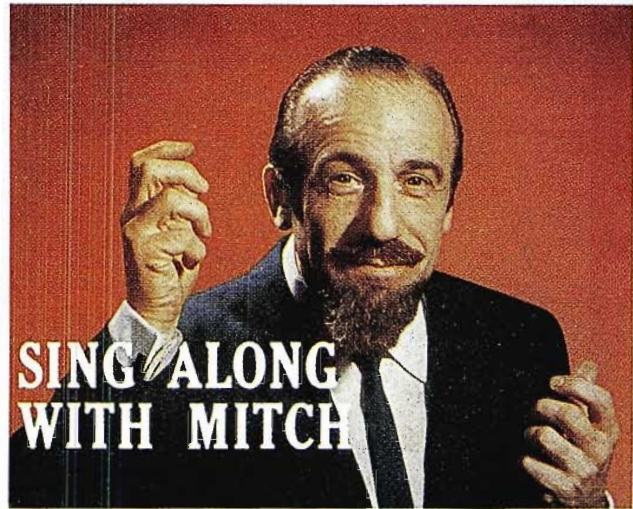
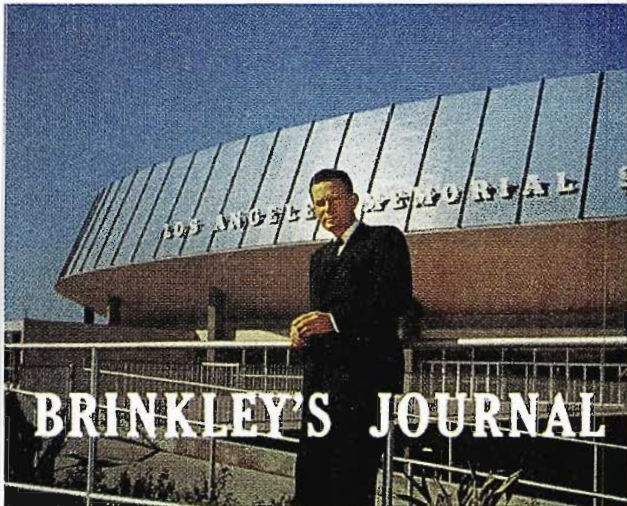


FIG. 4. Record-breaking TV hour now in color, Thursdays, 10 p.m.

The whole nation is singing along on Mitch's best-selling album. His NBC television hour broke all records last spring. So Mitch came back in color starting Thursday, September 28, for a full 52 weeks.

The All-American girl, DINAH SHORE, appears on Fridays, 9:30 to 10:30. She alternates with the BELL TELEPHONE HOUR. Big musicals featuring big stars, such as Robert Preston, cover the gamut from classical to cool.

#### Newest Color Shows

First, BULLWINKLE, a delightful kid's show featuring color cartoons in prime time, Sundays, 7 to 7:30.

DISNEY'S WONDERFUL WORLD OF COLOR, Sundays, 7:30 to 8:30. This is a delightful series, incorporating live actions and cartoons. It's done in color as only that master artist can do it.

At 10 to 11, Sunday, the DuPONT SHOW OF THE WEEK—in color. In the

same time period, THEATRE '62, live color dramatizations of David O. Selznick's celebrated all-time hits. (DuPont and Selznick shows account for two color shows per month.)

A new first-rank comedian, BOB NEWHART, started on NBC-TV in color, October 11. He's on 10 to 10:30, Wednesdays.

Bob Newhart is followed at 10:30 by DAVID BRINKLEY'S WEEKLY JOURNAL, the new prime-time news column. It's the first time a regularly scheduled news show is seen in color. Included are on-location color films taken all over the world.

Saturday nights from 9 to 11, NBC presents a series of post-1950 major motion pictures—at least half are big technicolor productions. In the first 15 weeks, through December 30, ten were telecast in color.

One of the newest hits, LARAMIE, is now seen in color on Tuesdays at 7:30 to

8:30. This western provides countless opportunities for magnificent color.

Another hour-long adventure series that has been colorized is WELLS FARGO, seen on Saturdays from 7:30 to 8:30.

#### Impact of Color Programming

Weekly color hours during prime time were considerably greater during 1961—an increase of 62 per cent.

In 1960, over 1000 hours of color were programmed. In 1961, there were 1630 hours of the best in color.

A comparison of hours, however, doesn't tell the whole story of quality and audience appeal of these color programs.

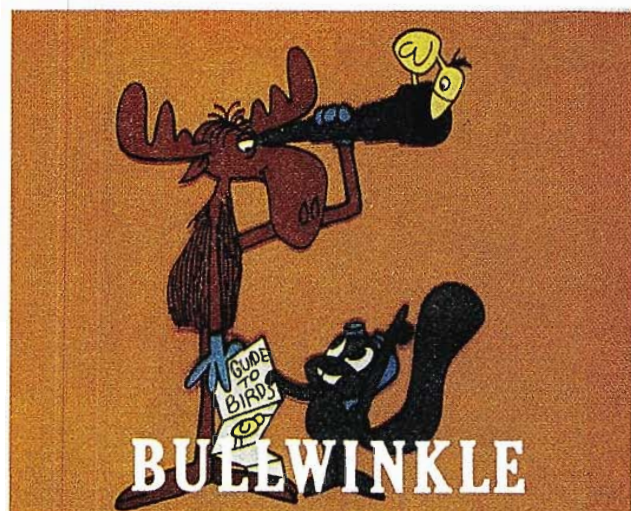
Comparison of prime evening time Home-Hours (the audience level of the programs times the number of hours of color) reveals that the latest color schedule delivers twice as many Home-Hours per week.

In terms of weight and balance, this newest color schedule is probably the best yet.

S	M	T	W	T	F	S
MEET THE PRESS			PERRY COMO			WELLS FARGO
BULLWINKLE	PRICE IS RIGHT	LARAMIE	BOB NEWHART	SING ALONG WITH MITCH	AT & T / DINAH SHORE	
DISNEY			BRINKLEY'S JOURNAL			
BONANZA						SATURDAY NIGHT FEATURE FILMS
DUPONT / SELZNICK						
JACK PAAR						

FIG. 5. Weekly Night-Time Color Schedule,

FIG. 6. New children's color show, Sundays, 7 p.m.





# NEW 5KW VHF TELEVISION TRANSMITTER

New Extremely Compact Design Features Stability  
of Operation and Low Power Consumption.  
Includes Built-in Remote Control

by H. E. SMALL

*Broadcast Transmitter Engineering*

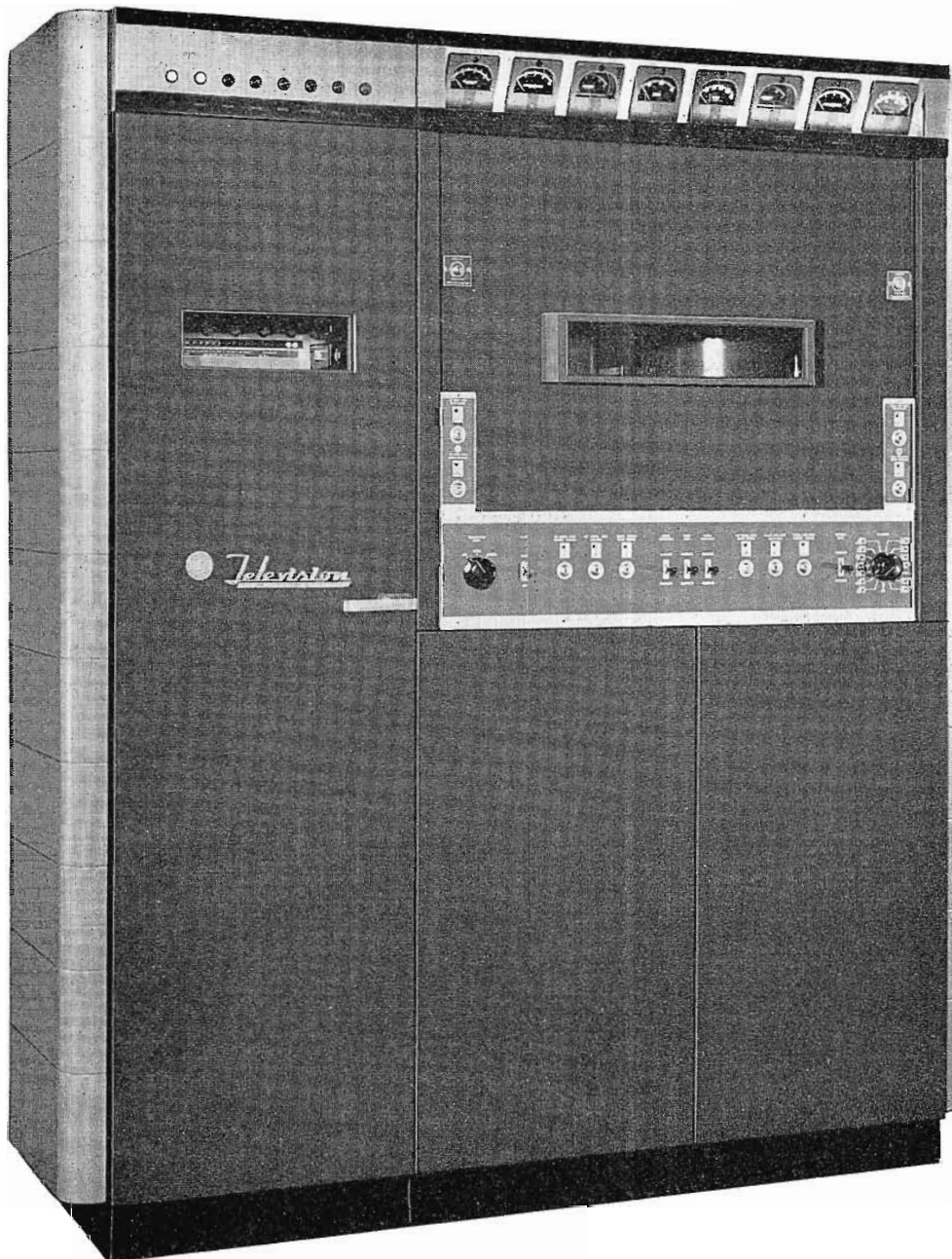


FIG. 1. Type TT-5BH 5 kw VHF TV Transmitter occupies only two cabinets. All operating controls and driver circuits are contained in front. Small cabinet at left contains control circuitry, larger cabinet contains exciter, modulator, and r-f circuits.

The TT-5BH is a new 5 kw, high channel VHF television transmitter requiring less than half the floor space of most 5 kw transmitters presently in operation. A great saving in power consumption is obtained from tubes that require very little driving power. All the outstanding features of RCA's new line of television transmitters have been included in the TT-5BH, and reliability has been further enhanced with silicon rectifier power supplies. Whether the TT-5BH is used as the main transmitter, as a driver for high-power amplifiers or as a standby transmitter, its many advantages are unequalled by other existing transmitters.

#### **Economical Installation**

Three years ago the space-saving 2 kw transmitter, the TT-2BH, was introduced. Now a 5 kw transmitter with the same physical size as the TT-2BH is available. In fact, the same typical floor plans can be used, since the same harmonic filters and vestigial sideband filter are used.

The TT-5BH can be placed in a corner of the room, since it is only necessary to leave walking space around the front and one side of the transmitter. It is also possible to separate the front line racks from the rear enclosure and place them in a different location. Almost any existing transmitter room will accommodate the TT-5BH; and in many places it can be worked in with existing equipment.

#### **Full Accessibility**

The control circuits, exciter, modulator, and r-f circuits are all contained in the front line racks. An aisle is provided inside the rear enclosure directly behind these racks. The access to this aisle is through an interlocked door on the left side of the transmitter.

To enter the enclosure, it is necessary to open a knife switch which has a long handle extending across the doorway. This switch opens the primary circuit of the high voltage plate transformer for added safety. A fail-safe automatic grounding



contactor shorts the large filter capacitors whenever an interlock is opened.

All components inside the enclosure are readily accessible. The high voltage transformer, heavy filter components, and blower are on the floor to the rear of the aisle. The blower is completely enclosed by a sound-insulated box to effectively reduce the noise in the transmitter room. All the intake air passes through replaceable filters.

The low-voltage power supplies, the high-voltage rectifiers and the plate contactor are mounted on the rear panel of the enclosure and are accessible from the aisle inside. Preformed cables are used for connections between the front line racks and the components at the rear of the enclosure.

### Advanced Circuitry

The exciter accurately controls the visual carrier frequency and the 4.5 mc separation between aural and visual carriers. This exciter has an excellent performance record in the TT-2BH Transmitter.

There are only two stages following the exciter in the aural transmitter. The first is a 4CX300A tripler which drives a 4CX5000A class "C" amplifier to produce an output of 2.75 kw. In the visual transmitter, three stages follow the exciter. A 7034 tripler stage drives a 4CX300A class "C" amplifier which in turn drives a 4CX5000A modulated amplifier.

Each tube following the exciter is protected by a fast-acting overload relay in its cathode circuit. Fast overload protection is also provided for the rectifiers in each power supply, as well as thermal overload protection for the transformers.

To aid tuning and maintenance, the voltages and currents of each stage are metered on front-panel meters.

### Designed for Color

The new visual modulator in the TT-5BH was designed for outstanding color performance, reliability, and ease of servicing. The same basic circuitry, proven by

FIG. 2. Control circuits are grouped in this cabinet. Status lights are on panel above door. Auxiliary switches, breakers, overload and auxiliary relays are mounted inside. Overload indicating lights are located behind glass panel in door.

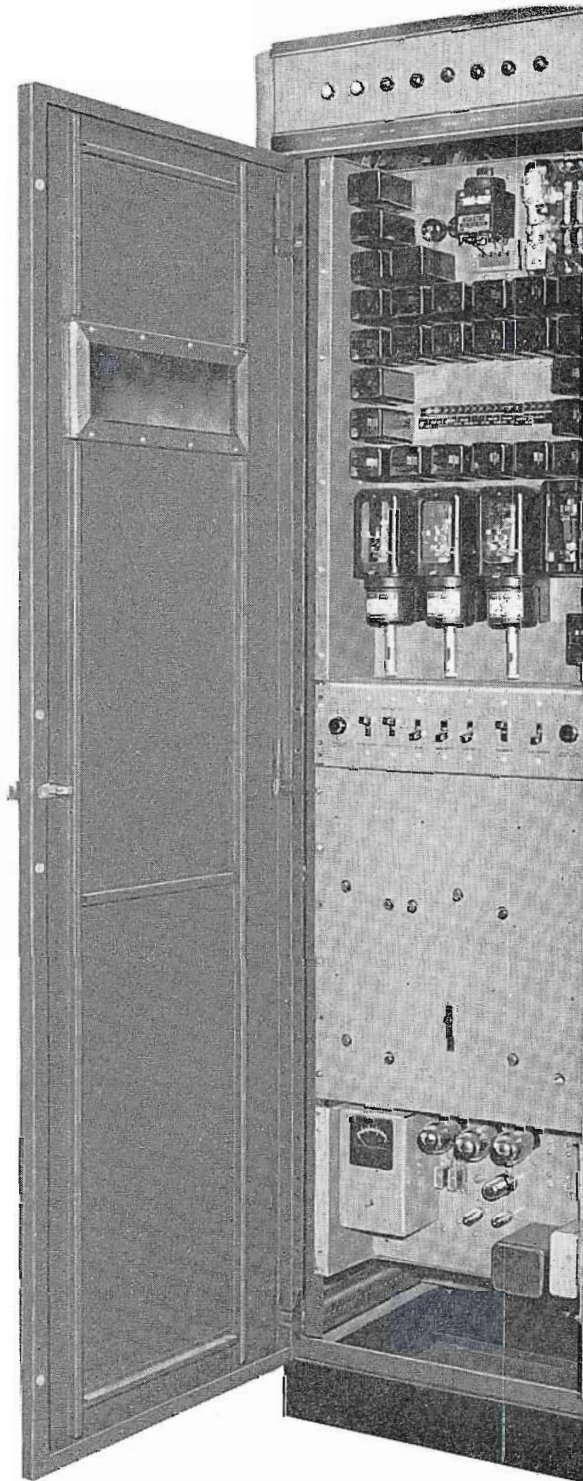
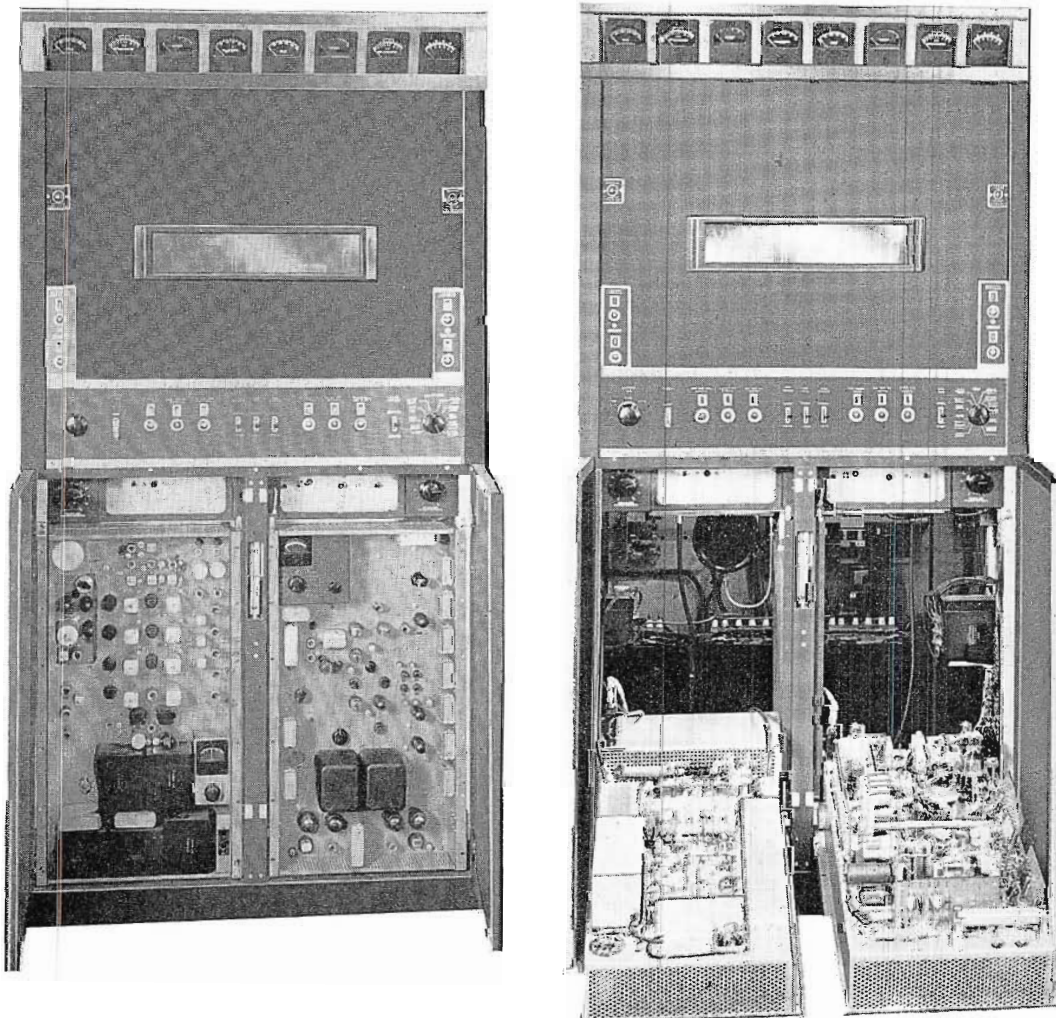


FIG. 3. Note accessibility from front of newest RCA TV Transmitter. At left, "Dutch" doors open to reveal exciter and modulator chassis. At right, these chassis, which are hinged on the bottom, are in lowered position to facilitate servicing. All important meters are mounted on a sloping panel at the top, with built-in lighting. Tuning and operating controls are mounted on waist-height panel above dutch doors.



many years of satisfactory performance in several hundred earlier transmitters, has been incorporated in this modulator.

An extremely stable clamp circuit and built-in linearity correction are features that contribute to the excellent color performance of the transmitter. Adjustment and servicing of the modulator are made easier by using test jacks that make it easy to observe the waveform at each stage with an oscilloscope.

### Economical Operation

One of the salient features of the TT-5BH is its extremely low power consumption. The input power requirement is about 70 per cent of that of some of the earlier 5 kw high-band television transmitters. This saving is made possible by using low-drive, high-gain tubes in the r-f stages and



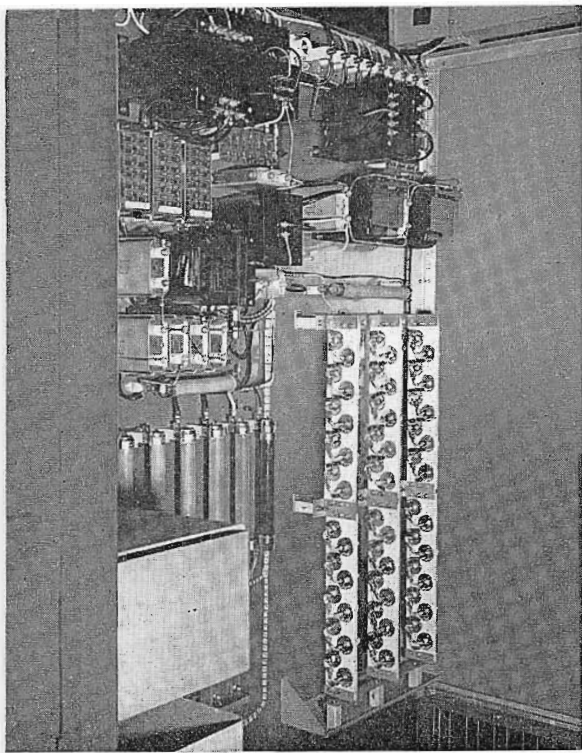


FIG. 4. Interior view of rectifier enclosure. High voltage silicon rectifiers are mounted on rear panel, easily accessible from aisle. They extend range of operating temperature and increase reliability of operation.

by using common power supplies. These high gain tubes have very low plate dissipation; therefore little power is wasted, and cooling is greatly simplified.

#### Solid-State Power Supplies

Silicon rectifiers used in all power supplies provide proven reliability. The rectifiers rarely need replacing during the life of the transmitter and they do not require close temperature control normally associated with mercury vapor tubes. The rectifiers need no filament power, thus saving components and power consumption, and there is no danger of arc starvation common to vapor tubes.

#### Built-In Remote Control

The remote control provisions built into the TT-5BH make possible the operation

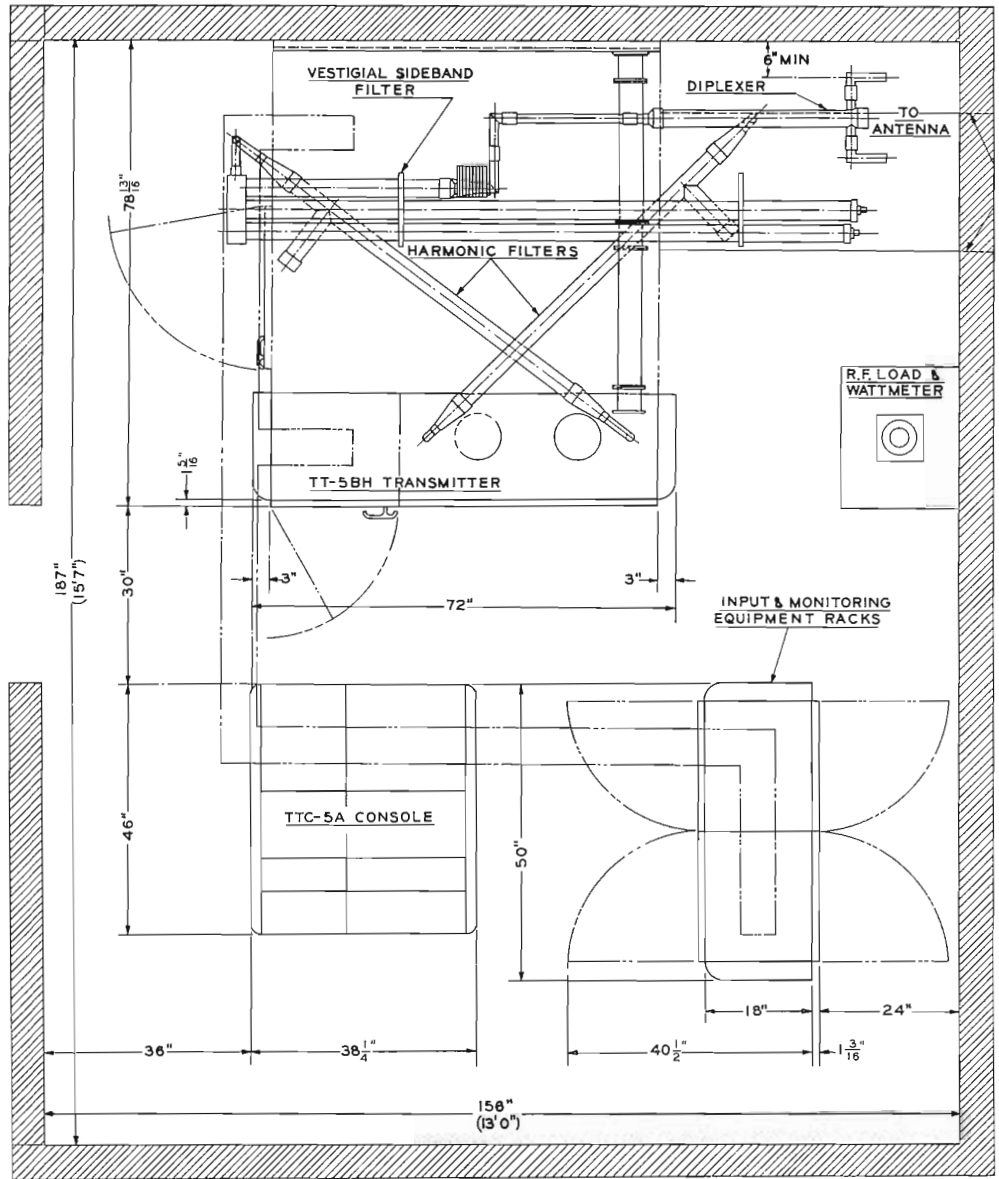
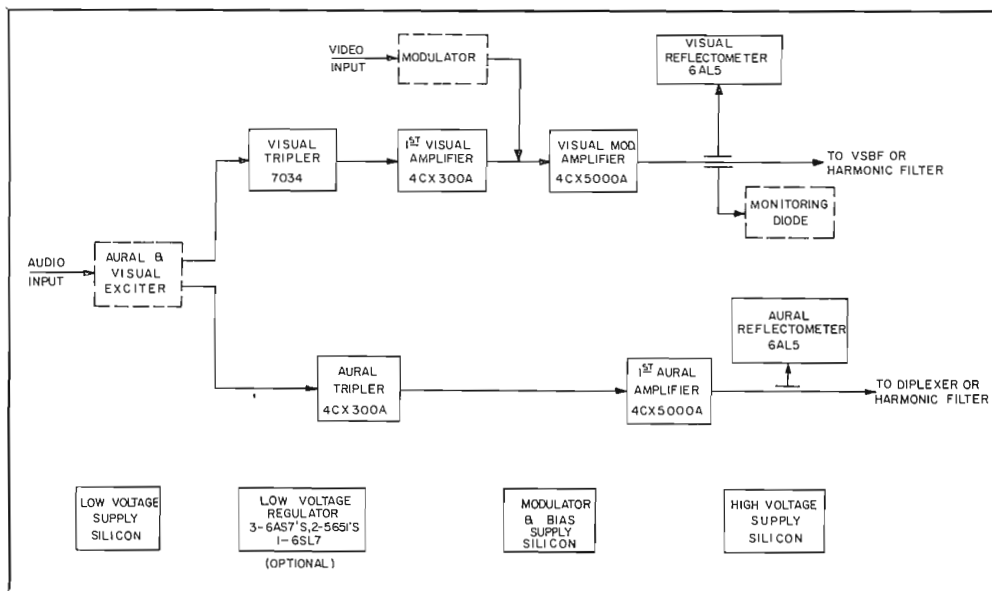


FIG. 6. Typical floor plan for TT-5BH.

FIG. 5. Block diagram of TT-5BH.



of the transmitter from a distant location by merely adding the necessary external control equipment. If the FCC should authorize remote control of television transmitters, no delay would be encountered since modification of the TT-5BH is not necessary. These provisions can also be used for complete operation of the transmitter from the control console.

#### Serves Many Uses

This new 5 KW transmitter presents an extremely compact and economical package for replacing outdated transmitters or for a new medium-coverage station. A power amplifier can be added at any time to increase power. The great reduction in floor space requirements with improved accessibility, low-cost operation, remote control provisions and proven dependability are some of the features which make the TT-5BH ideal for use as a main transmitter, or as driver for a high-power amplifier.





"In the studio or on the road, our picture quality is consistently tops—we're ready to shoot anything with RCA TV Tape Equipment. We've used our mobile Recorders under all conditions—yet we get studio-quality pictures every time. Clients rave about the lifelike quality of our tapes!"

***"Even at 60 mph  
we get studio-quality  
pictures—with  
RCA TV TAPE!"***

—says Henry Alexander, President  
VIDEO TAPE UNLIMITED

The mammoth 40-foot mobile unit pictured here can make studio-quality tapes while traveling at 60 miles per hour. Designed and equipped by RCA for Video Tape Unlimited, it includes four cameras, two TV tape recorders, switching and special effects, and control equipment. Specially-designed platforms at front and rear of the bus carry two cameramen. Cameras also may be set up on the roof so that shooting is possible from any vantage point. Completely self-contained—this mobile unit has everything a well-equipped TV unit should have—including power generator.

Why is RCA equipment the big choice among producers and broadcasters who demand the very best? There are several reasons:

RCA TV Systems are matched—electrically and mechanically. RCA makes it practicable to get everything from a single, reliable source. RCA equipment uses easy-to-find tube types, standard parts. RCA equipment is designed, built, and operated in accordance with proved broadcast procedure. And RCA equipment is backed up by top engineering counsel and service everywhere.

See your RCA Representative or write to RCA, Broadcast and Television Equipment, Building 15-5, Camden, N. J.



The Most Trusted Name in Television  
RADIO CORPORATION OF AMERICA







FOR...FINEST TV PICTURES!

# TK-12

---

4½ INCH I.O.  
CAMERA

*For Sales Impact • Unvarying Quality • Creative Effects*

The RCA TK-12 is the camera you need, if you want the finest in television tapes, live programs, and commercials. It produces pictures with higher resolution, lower noise, and improved grey scale. Self-adjusting circuits prevent deterioration in picture quality, and RCA engineering has designed features, such as viewfinder display of special effects, and remote iris control, that enable you to do more with the TK-12.

You can use the TK-12 for making dramatic demonstrations of clients' products. Its big 4½ inch I.O. tube (plus advanced engineering) provides big picture quality, rivaling the finest photography. Improved grey scale preserves delicate differences in shading. Pictures are *naturally* free from "halo" and "blooming", without need for product spraying or painting. You can control contrast and mood as never before. You can produce tapes and live commercials that show the client's product sparkling in life-like detail.

Self-adjusting circuits, built into the TK-12, eliminate variations in performance. These circuits compensate

for changes in temperature, line voltage, and aging. Furthermore, long warm-up time is a thing of the past. Pictures are ready for use within minutes after the camera is turned on. This new mode of operation saves set-up time, reduces the number of controls, and assures unvarying picture quality.

RCA engineering has introduced many features that make the TK-12 the most versatile of cameras. An 8 inch viewfinder provides a much larger and brighter picture (200 ft. lamberts). Video effects can be seen on the viewfinder, permitting cameraman to adjust camera position for best advantage in overall effect. Remote iris control permits adjusting all lenses simultaneously, merely by turning a knob.

The RCA TK-12 is the camera you need if you want the finest picture in town. Its new and different look will convince clients that your studio is equipped with the best. Ask your RCA Representative for all the details. Or write to RCA, Broadcast and Television Equipment, Building 15-5, Camden, N. J.



The Most Trusted Name in Television  
RADIO CORPORATION OF AMERICA



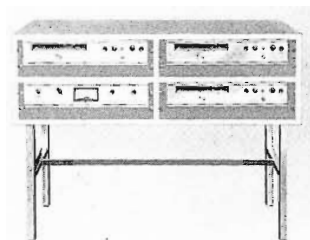
# New RCA Cartridge Tape System with "TRIP CUE"



Here's the cartridge tape system with something new—*trip cue!* This unique feature allows you to record a special trip-cue tone that, during playback, can be used to start the next device in an automatic or semi-automatic system, with split-second timing. (In TV operations it may be used to advance slide projectors.)

Delayed broadcast, spot announcement campaigns, production aids, themes, station breaks can be handled by the RT-7A with a minimum of effort. Cartridge is selected, placed in a playback unit, forgotten until "Air" time, then instantly played at the flick of a button. Cueing and threading are eliminated.

Check this handsomely-styled equipment against any other for compactness and design... Provides transistor circuitry, low power consumption, simplicity of operation! It's one more in a growing line of value-packed new products for radio and television stations from the pioneer in broadcasting. See your RCA Broadcast Representative. Or write to RCA Broadcast and Television Equipment, Building 15-5, Camden, N. J.



Typical packaging is this attractive four-unit console with single BA-7 Cartridge Tape Record and Playback Amplifier and three Cartridge Tape Decks, as illustrated.

Separate units of this system available are the Record and Playback Amplifier, and the Cartridge Tape Deck. A Cartridge Storage Rack is also available.



The Most Trusted Name in Electronics  
RADIO CORPORATION OF AMERICA



# AN EXAMINATION OF THE POWER LOSSES IN TOWER ANTENNAS AS A FUNCTION OF GALVANIZING

by DR. GEORGE H. BROWN

*Vice-President, Research and Engineering  
Radio Corporation of America, Princeton, New Jersey*

Occasionally, in even an otherwise well-engineered antenna project, some small factor is neglected, the designer assumes for himself a false expertness, or a grumpy pixie lends a hand. If the resulting field intensity is too low, consternation prevails, common sense departs, and fantastic theories flower. One can usually count on suggestions concerning harmonic radiation from the guy wires, resonance in something, horizontally polarized radiation, or loss resistance in the tower. A damaged antenna ammeter is more likely.

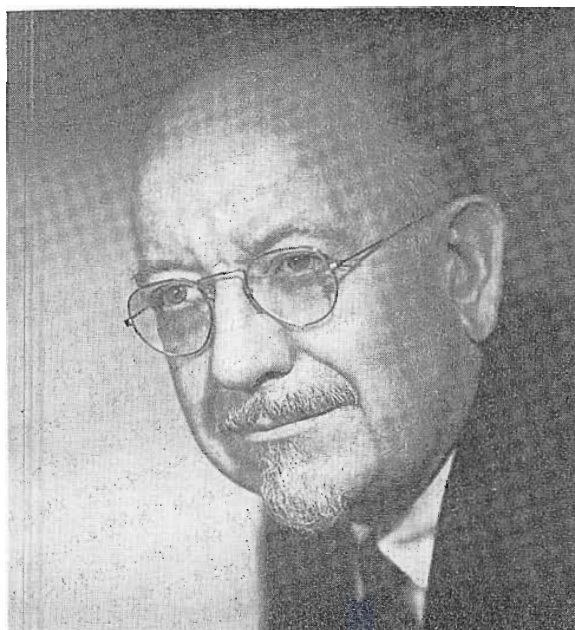
Some time ago, in a case like this, questions were raised regarding the conduction loss in a galvanized steel tower. Ample speculation was assured, since little was known of the electrical constants of the steel or of the thickness of galvanizing. After listening to a number of fanciful proposals which involved the concepts of X-rays, electron microscopes, ultrasonics, and Maxwell's bridge, the writer undertook an independent and relatively unsophisticated investigation which made use of only a Q-meter. The results of this investigation may appeal to some readers.

### Experimental Data

The tower in question was triangular in cross section and each vertical member was a galvanized steel cylinder one inch in diameter. Two cylinders, each several inches long, were cut from a tower section provided by the manufacturer. The galvanizing was stripped from one cylinder, while the other was preserved intact. A third cylinder of copper and of the same dimensions was prepared.

A multi-turn coil of copper tubing, with an approximate diameter of two inches was constructed and mounted on the terminals of a Q-meter.\*

\* Type 160-A, Boonton Radio Corporation, Boonton, N. J.



Dr. George H. Brown

The resistance of the coil was measured with the Q-meter, at frequencies of 1.0 megacycle and 4.5 megacycles. Next, the copper cylinder was mounted coaxially within the coil and the resistance of the coil was again measured. From the latter measurement, we subtract the resistance of the coil alone to obtain a quantity we shall call  $\Delta R$ . Similarly, other values of  $\Delta R$  were obtained by substituting the galvanized steel cylinder for the copper cylinder, and again by using the stripped steel cylinder. The results of these measurements are displayed in Table I.

<b>TABLE I</b>		
<b>MEASURED INCREMENTAL RESISTANCE, <math>\Delta R</math> (ohms)</b>		
Frequency (megacycles) .....	1.0	4.5
Copper Cylinder .....	0.04	0.079
Galvanized Steel Cylinder .....	0.229	0.251
Stripped Steel Cylinder .....	(Q too low to record) 2.15	



Frequency (megacycles) .....	1.0	4.5
Copper .....	1.724	1.724
Zinc .....	5.8	5.8
Galvanized Steel .....	56.6	17.42
Steel .....	1278.	1278.

### Experimentally Determined Electrical Constants of the Material

It may be shown<sup>1</sup> that for a specific configuration and frequency, the incremental resistance is proportional to the square root of the product of the relative permeability and the resistivity of the material of which the cylinder is composed. That is,

$$\Delta R = K \sqrt{\mu p} \quad (1)$$

For the copper cylinder, the relative permeability,  $\mu$ , is unity. From the results of many experimenters, we know that the resistivity of copper at 20°C is  $1.724 \times 10^{-6}$  ohm for a centimeter cube. Then, from (1), and the measured value of  $\Delta R$  for copper from Table I, we find

$$K^2 = \frac{(\Delta R)^2}{p} = \frac{0.079^2}{1.724 \times 10^{-6}} = 3625. \quad (2)$$

at a frequency of 4.5 megacycles. Now using this value of  $K^2$  and  $\Delta R = 2.15$  in equation (1) we find

$$\mu p \text{ (steel)} = \frac{2.15^2}{3625} = 1280 \times 10^{-6} \text{ ohms} \quad (3)$$

at 4.5 megacycles. In the case of metals which have a permeability greater than unity, we are unable by this method to unscramble the resistivity from the product of resistivity and permeability. However, for the purposes of this investigation, no hardship is imposed.

<sup>1</sup> George H. Brown, Cyril N. Hoyler, and R. A. Bierwirth, *Theory and Application of Radio-Frequency Heating*, D. Van Nostrand Company, Inc., 1947, p. 105.

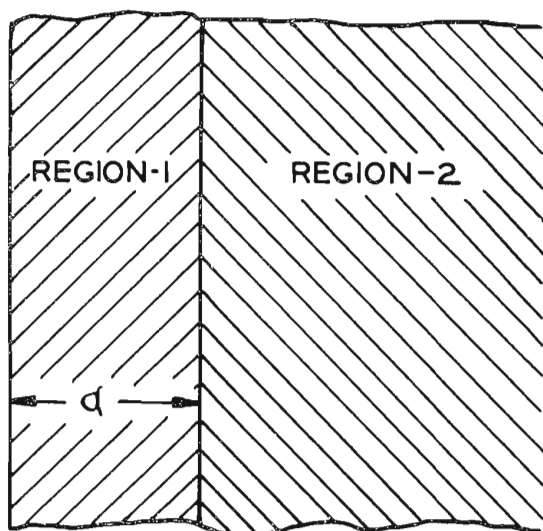


FIG. 1

Unfortunately, the value of  $Q$  prevailing for the steel cylinder at one megacycle was too low to read with reasonable accuracy. However, it seems reasonable to assume that the permeability-resistivity product for this homogeneous material remains constant over a wide range of frequencies.

The galvanized steel cylinder presents a more complex picture. Here, some of the surface current flows in the zinc surface layer and some penetrates into the steel. The relative distributions change with frequency in a complex fashion. Hence substitution into equation (1) will yield an *equivalent*  $\mu p$  value which pertains only to the frequency at which the measurement is made. These equivalent values are shown in Table II. It should be noted that the values for copper and zinc were taken from existing tables of resistivity.

When high-frequency current flows along the surface of a conductor, it encounters a surface resistance of  $p/s$  ohms in a patch one centimeter in length and one centimeter in width, where  $s$  is the skin thickness of the metal at the frequency in question. But

$$\frac{p}{s} = 2\pi \sqrt{10^{-9} f \mu p} \text{ ohms} \quad (4)$$

where  $f$  is the frequency in cycles and  $\mu p$  is the permeability-resistivity product in ohms. The surface resistance, calculated from the data of Table II, is displayed in Table III.

### Thickness of Galvanizing

Let us next examine a state of affairs as shown in Figure 1 where Region 1 is a layer of zinc of thickness  $a$  centimeters and Region 2 is a thick inner block of steel.

Let

$\mu_1$  = the relative permeability of the metal in Region 1 = unity for zinc.

$p_1$  = the resistivity of the metal in Region 1 =  $5.8 \times 10^{-6}$  ohms for zinc.

$s$  = the skin thickness of the metal in Region 1.

$\mu_2$  = the relative permeability of the steel in Region 2.

$p_2$  = the resistivity of the steel in Region 2.

$\mu_2 p_2 = 1278 \times 10^{-6}$  ohms from Table II.

Then the ratio of the surface resistance of the laminar condition to the surface resistance of a thick zinc sheet is<sup>2</sup>

$$\text{Resistance Ratio} = D/B \quad (5)$$

<sup>2</sup> loc. cit., pp. 69-71.



TABLE III		
SURFACE RESISTANCE (micro-ohms)		
Frequency (megacycles) .....	1.0	4.5
Copper .....	260.5	553.
Zinc .....	478.	1012.
Galvanized Steel .....	1490.	1760.
Steel .....	7090.	15,020.

where

$$\begin{aligned}
 D = 1 - \epsilon - \frac{2a}{s} + \frac{\left(1 - \sqrt{\frac{\rho_1}{\mu_2 \rho_2}}\right)^2}{\left(1 + \sqrt{\frac{\rho_1}{\mu_2 \rho_2}}\right)^2} \left( \epsilon - \frac{2a}{s} - \epsilon - \frac{4a}{s} \right) \\
 + \frac{2 \left(1 - \sqrt{\frac{\rho_1}{\mu_2 \rho_2}}\right)}{\left(1 + \sqrt{\frac{\rho_1}{\mu_2 \rho_2}}\right)} \epsilon - \frac{2a}{s} \sin \frac{2a}{s} \\
 + \frac{4 \sqrt{\frac{\rho_1}{\mu_2 \rho_2}}}{\left(1 + \sqrt{\frac{\rho_1}{\mu_2 \rho_2}}\right)^2} \epsilon - \frac{2a}{s} \quad (6)
 \end{aligned}$$

and

$$\begin{aligned}
 B = 1 + \frac{\left(1 - \sqrt{\frac{\rho_1}{\mu_2 \rho_2}}\right)^2}{\left(1 + \sqrt{\frac{\rho_1}{\mu_2 \rho_2}}\right)^2} \epsilon - \frac{4a}{s} \\
 - \frac{2 \left(1 - \sqrt{\frac{\rho_1}{\mu_2 \rho_2}}\right)}{\left(1 + \sqrt{\frac{\rho_1}{\mu_2 \rho_2}}\right)} \epsilon - \frac{2a}{s} \cos \frac{2a}{s} \quad (7)
 \end{aligned}$$

This resistance ratio is shown in Fig. 2 as a function of a/s.

We next enter Table III and find, at one megacycle, a resistance ratio of the galvanized steel to zinc of  $1490/478 = 3.12$  which corresponds in Fig. 2 to a value of 0.275 for a/s. The skin thickness of zinc is found, from the relation

$$s = \frac{1}{2\pi} \sqrt{\frac{\rho}{10^{-9} f}} \text{ centimeters} \quad (8)$$

where f is the frequency in cycles and  $\rho$  is the resistivity in ohms, to be 0.0048 inch. Thus it is easy to calculate the thickness of the zinc to be  $0.275 \times 0.0048 = 0.00132$  inch or 1.32 mils.

As a cross check, we again go to Table III and find the resistance ratio at 4.5 megacycles to be 1.74, a value which yields  $a/s = 0.565$  in Fig. 2. The skin thickness of zinc at 4.5 megacycles is 2.27 mils, so the thickness of the zinc is indicated to be 1.28 mils, which is within three per cent of the value we found at one megacycle.

### Losses in Tower Antennas

The surface resistance values of Table III are directly applicable to calculation of the conduction losses in a tower antenna. For instance, the resistance per centimeter of length of a cylinder is  $\left(\frac{\rho}{s}\right) \cdot \frac{1}{\pi d}$  where  $\rho/s$  is the surface resistance, in ohms, from Table III and d is the diameter of the cylinder in centimeters. For a triangular cross-section tower, with three vertical legs, the resistance per unit length would be one-third of the above value, or

$$r = \left(\frac{\rho}{s}\right) \cdot \frac{1}{3\pi d} \quad (9)$$

If the antenna is one-quarter wave tall, the loss resistance is

$$R_L = \frac{r \lambda}{8} \quad (10)$$

where  $\lambda$  is the wave length in centimeters. Assume the frequency to be one megacycle and the tower legs to be one inch in diameter. Then  $R_L = 156.8 (\rho/s)$ . For an ungalvanized tower,  $R_L$  is 1.11 ohms, while the galvanized tower has a loss of 0.233 ohm. Tripling the thickness of galvanizing would reduce the loss to about 0.075 ohm.

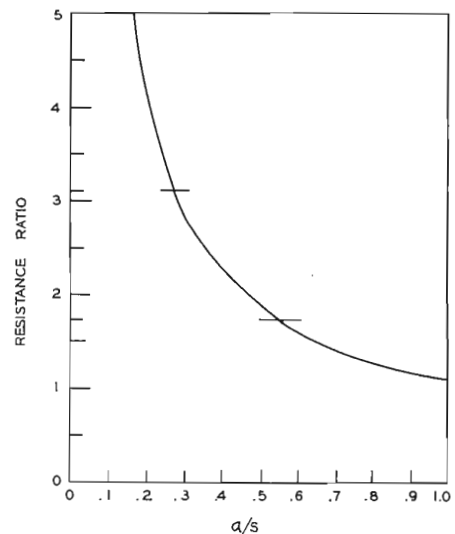


FIG. 2

### Conclusion

A method of determining the electrical properties of tower structures by a simple measuring technique has been described. From these data, simple calculations yield a fair estimate of conduction losses in broadcast tower antennas.



# WGN

## COLOR HOUSE



## NATION'S TOP INDEPENDENT PLANS 1700 HOURS OF LOCAL COLOR IN 1962

In January 1961, WGN moved to its new Mid-America Broadcast Center, and began operations in what will eventually become an all-color television center.

The new 2-story facility is hailed as one of the largest and finest in the U.S.A. It contains over 100,000 square feet of floor space, situated on a 13-acre site, some 15 minutes from Chicago's downtown area.

Doors to the new radio-TV building were formally opened on June 27 by J. Howard Wood, President of the Tribune Company and WGN, Inc.,—also publisher of the world-famous Chicago Tribune.

(WGN radio began on June 1, 1924, when the late Col. Robert R. McCormick acquired station WDAP and changed the

call letters to WGN, standing for the Tribune's slogan "World's Greatest Newspaper".)

WGN'S new broadcasting center was conceived and is built for color television. Studios are designed for color operation, containing facilities for producing both live commercials and programs in color. In addition, a complete mobile unit is provided for remote colorcasts. At present, WGN is one of America's leading color stations, programming more than 1,000 hours of color shows per year, since 1959.

### Color Programming

The major part of the 1400 hours in color for 1961 was done live from either WGN studios or remotes.

WGN-TV televised 122 baseball games in color during 1961. This was the second year that viewers saw major league games in tint. There were 43 daytime home games of the Chicago White Sox and 77 of the Chicago Cubs, together with 2 city series games. These were colorcast directly from Wrigley Field and Comiskey Park, using the Color TV mobile unit with four color cameras and color Microwave Link.

Other color programs, live studio shows, daily Monday thru Friday, include:

Treetop House	9-9:30 am
Bozo Circus	12-1:00 pm
Bugs Bunny	3:30-4:00 pm
Garfield Goose	5-5:30 pm
Dick Tracy	6:30-7:00 pm

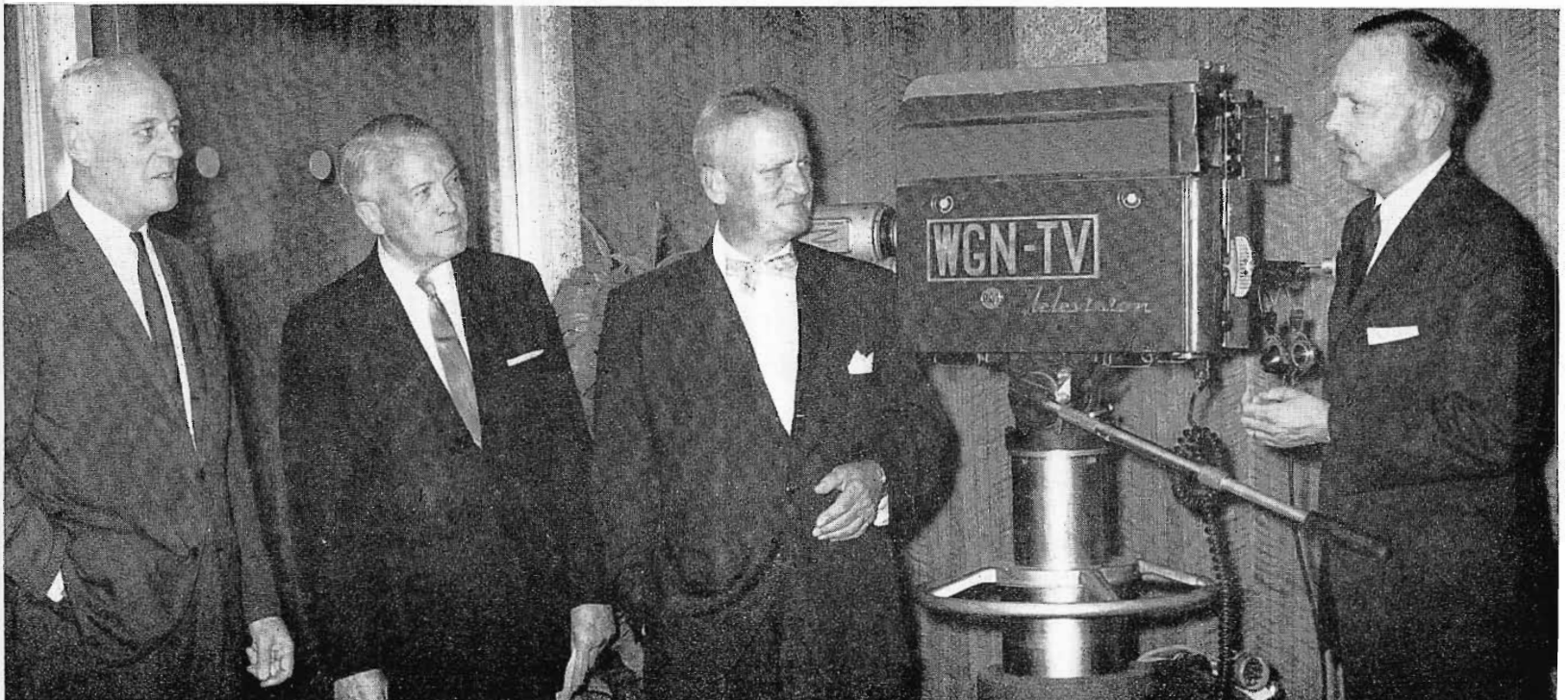




FIG. 1. WGN's new Mid-America Broadcast Center (left).

FIG. 2. (lower left) At dedication of WGN Broadcast Center were Ward L. Quaal, executive vice-president and general manager of WGN, Inc. (right) and J. Howard Wood, publisher of the Chicago Tribune and president of WGN, Inc. Also, T. Clifford Noonan and Marvin G. Probst, vice-president and president respectively of Graham, Anderson, Probst & White, who designed the broadcast center.

FIG. 3. (right) "Treetop House" is a daily program for pre-school children—with natural color sets of living plants and live animals.

### Children's Color Programs Pay Off

In TREETOP HOUSE, the pre-school children are entertained by Mary Jane Clark. There is a daily round of games, songs, and stories. Also an educational feature designed to develop an awareness of the world in youngsters. This is done by the planting of flowers and vegetables, the care and feeding of fish and animals. Color lends realism to this effort to stimulate the imagination of children.

The BOZO CIRCUS is complete with ringmaster and a band as well as Bozo the Clown. The atmosphere is that of the big top—colorful and spectacular. There are live animal acts and guest performers alternating with games and prizes. Chicago children are released from school, a class at a time, not only to enjoy this spectacle but also to report on the manner in which a television program is put on!

BUGS BUNNY is a color cartoon show with live wraparound. Dick Coughlan uses hand puppets to introduce the various cartoons. Dick also inserts the color commercials quite cleverly—carrying on conversations with his mythical friends.

The GARFIELD GOOSE with Frazier Thomas is a live puppet show in color. Garfield is a gander who has delusions of grandeur, believing that he is king of the United States! It's another amusing show for children.

The DICK TRACY color show includes new films of this famous character with live wraparound by Ray Rayner. He is Sergeant Pittibone, who carries on conversations with Dick Tracy (never seen).

These live color shows are filled up with sponsors. Several of these shows lead their time period, against network competition, and have a waiting list. This would prove that it pays to be what has been said of WGN, "The station is wild about color."







FIG. 4. "Bozo Circus" is a daily spectacular color production for the young of all ages. Children are released from school to attend, with teachers and parents.

FIG. 5. The Chicago Symphony Orchestra is heard each Sunday evening 9 to 10 p.m. on "Great Music from Chicago." In 1960 this program, televised live and in living color, won for WGN the coveted Peabody Award.



#### Night-Time Color . . . Clicks

Live programs in prime time include: MR. MAGOO on Wednesday, 7 to 7:30, and EXCLUSIVELY OUTDOORS on Thursday, 8 to 8:30.

Live color wraparound for the Magoo cartoon is provided by Mr. Ogelsby, who runs a delicatessen store and personally delivers orders to Mr. Magoo. Once there, Ogelsby is enticed by Magoo to view the color cartoons. Ratings show the adults go for this in a big way.

EXCLUSIVELY OUTDOORS is presented by Jim Thomas and designed for the sportsman and sportswoman. On-location color films are used to demonstrate hunting and fishing techniques all over the world. Color helps sell sporting goods to these devotees of the sports.

On Thursdays and Fridays at 10:15 color feature films are shown under title: WGN PRESENTS. This is part of the recent film package of post-1950 features acquired by the station. These color features are premiere showings for Chicago.

Another color film series "BEST OF THE POST" is presented, Thursdays at 8 p.m.

Altogether color programming for 1961 tops 1400 hours. Ratings are excellent. There are no red ink entries, no sustaining required. Color has more than paid its way—from the beginning.





FIG. 6. New "Dick Tracy" color cartoon show has a color wrap-around with realistic and colorful setting, featuring Sergeant Pettibone.

### Color Adds New Dimension

"WGN-TV has played a major role in color broadcasting", states Ward L. Quaal, Executive Vice-President and General Manager, WGN, Inc., "making its entry back in November, 1957, with a modest 30 hours.

"Since then, we telecast more than 400 hours of color in 1958, with a total of 1070 hours in 1959 and 1200 in 1960. This year, we expect to do 1400 of our programs in color and, on a projected basis, present 1700 hours of color in 1962.

"In the case of television, color has added a fourth dimension to the trio of sight, sound, and motion—a combination which no other medium can match.

"Both the networks and individual stations across the country have, with few exceptions, reached a "plateau" in sales development. There is only one ingredient to change this picture and that is the introduction, at every television station and on all three networks, of color on a full-scale basis.

"In my opinion, this will create a greater tune-in, will stimulate more interest in the medium and above all, will pave the way for a dramatic influx of new advertisers. The list of those who would use television for their advertising, if enough of it were in color, is limitless."

FIG. 7. During 1961 WGN colorcast 122 Chicago Cubs and White Sox daytime home baseball games directly from Comiskey Park and Wrigley Field.

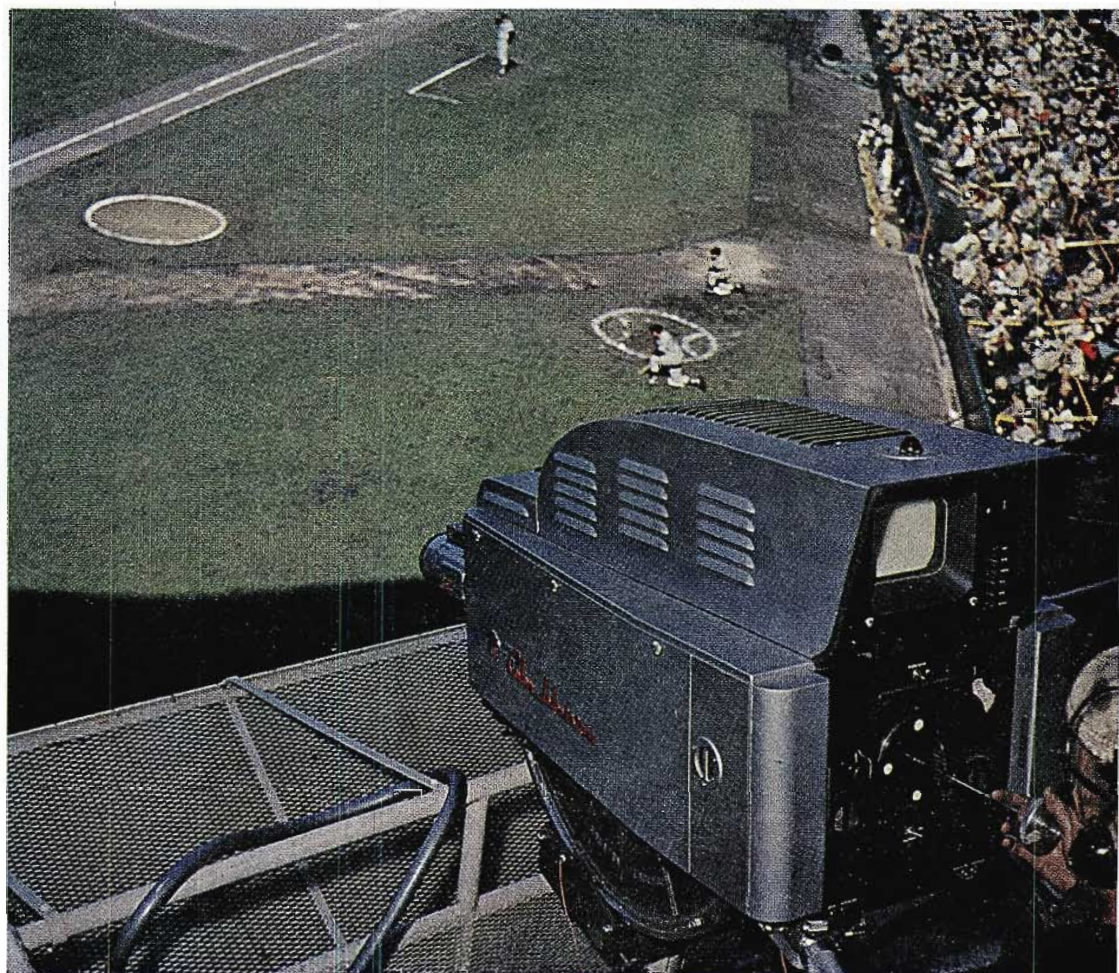






FIG. 8. Carl J. Meyers, vice-president and a director of WGN, Inc., whose design philosophy is reflected in the new building as well as the equipment system.

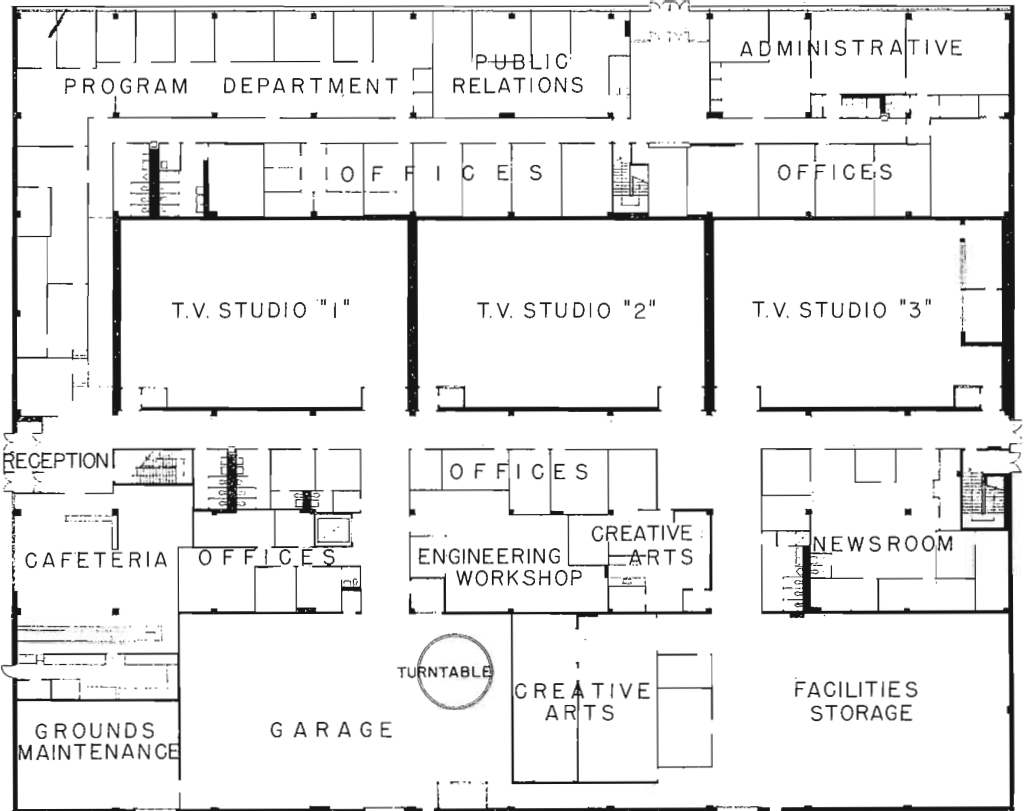


FIG. 10. First floor of WGN's new radio and television studio and office building.

### Color House

The new building is designed to comply with the operational requirements outlined by the station engineering staff, headed by Manager of Engineering, Carl J. Meyers, Vice-President and a director of WGN, Inc. In the new structure are located all radio and TV studios, together with 50 individual offices for administrative, engineering,

and sales functions. Facilities include film and news rooms, garage for mobile units, a video tape area, and a revolving stage to produce commercials for automobiles or agriculture equipment.

Outside there are beautiful landscaped areas together with parking space for some 300 cars. Inside is a 60-seat cafeteria and private dining rooms. Included are the nec-

essary machine and carpentry shops, dressing rooms, and talent areas.

The new building was designed by the architectural firm of Graham, Anderson, Probst & White, Inc. General contractor was the Gerhardt F. Meyne Company.

### Special Structural Features

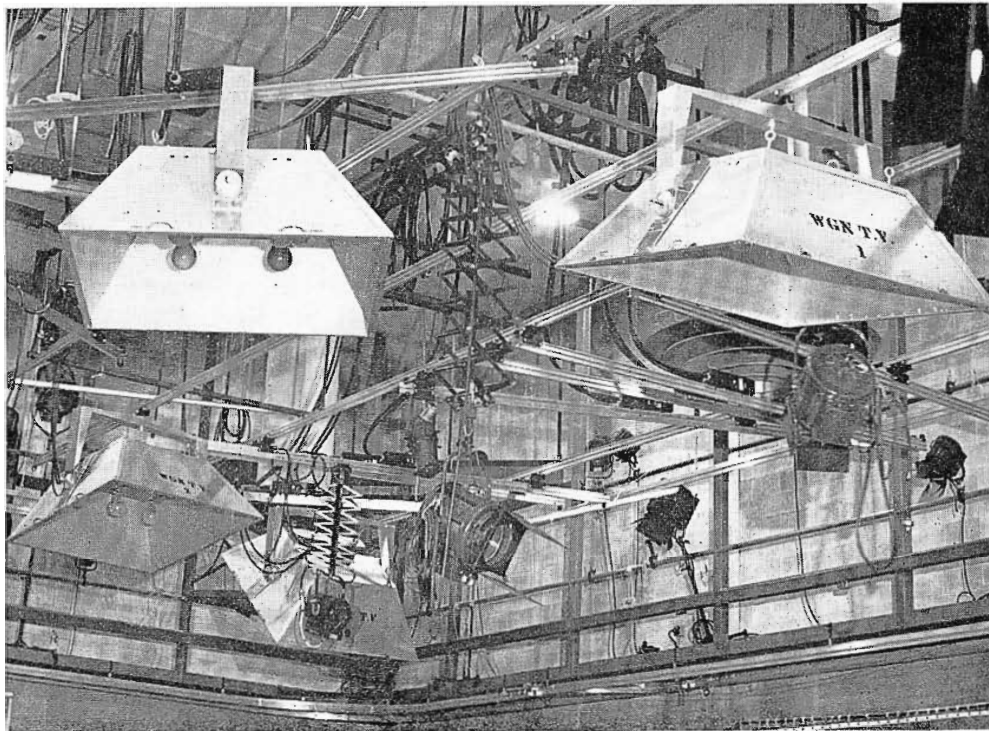
The reinforced concrete building exhibits a simple exterior of brick, aluminum and glass. Striking, however, are the structural features which isolate the three main TV studios from the building proper. Each studio, 72 by 47 ft., is, in effect, a building within a building. Each rests on its own caisson foundation—separate from that which supports the balance of the structure.

Each studio has its own separate walls, ceiling and roof framing. A control room, 15 ft. above studio floor level, gives virtually 100 per cent visual coverage of the studio. A steel grating catwalk follows the perimeter walls of each studio at the control room level. It can be reached from both the control room and the studio floor. It's useful for staging special lighting effects and for control room personnel.

### Acoustical Features

The building incorporates, for acoustical reasons, floating partitions, a door system with sound locks, and sound absorbing materials on studio walls and ceilings. On the walls, this material runs only half way to the 30 ft. ceiling, giving a pleasant "live" but tempered, resonant quality.

FIG. 9. Upper part of WGN studio showing "lighting tubs" and "the rail" system of mounting fixtures.





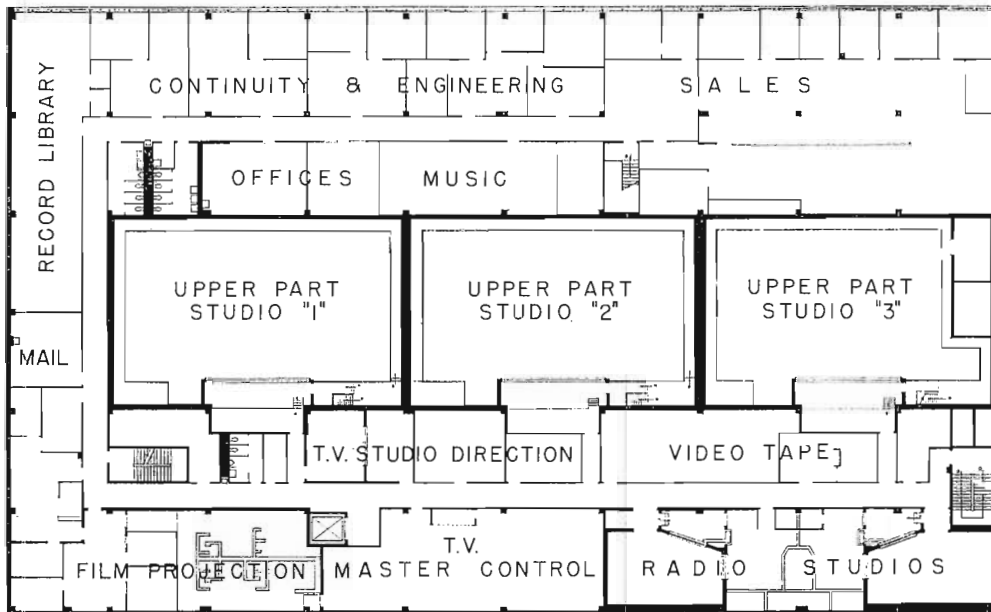


FIG. 11. Second floor of new building. All three TV studios are same size.

Special precautions were also taken with both mechanical and electrical equipment. In the mechanical area, special mountings are used for all pumps and motors. These mountings use spring isolators and floating concrete pads. Even the boiler is on a floating pad.

Flexible connections were used extensively and all piping and ductwork are hung to avoid direct contact with studio enclosures. A low-velocity air-conditioning system is employed, with sound attenuators in all ducts supplying air to the studios.

To eliminate noise from electrical service, lighting ballasts are located remote from the studio. Flexible connections are used between the building and walls of the studio. Transformer noises are isolated by use of sound dampeners.

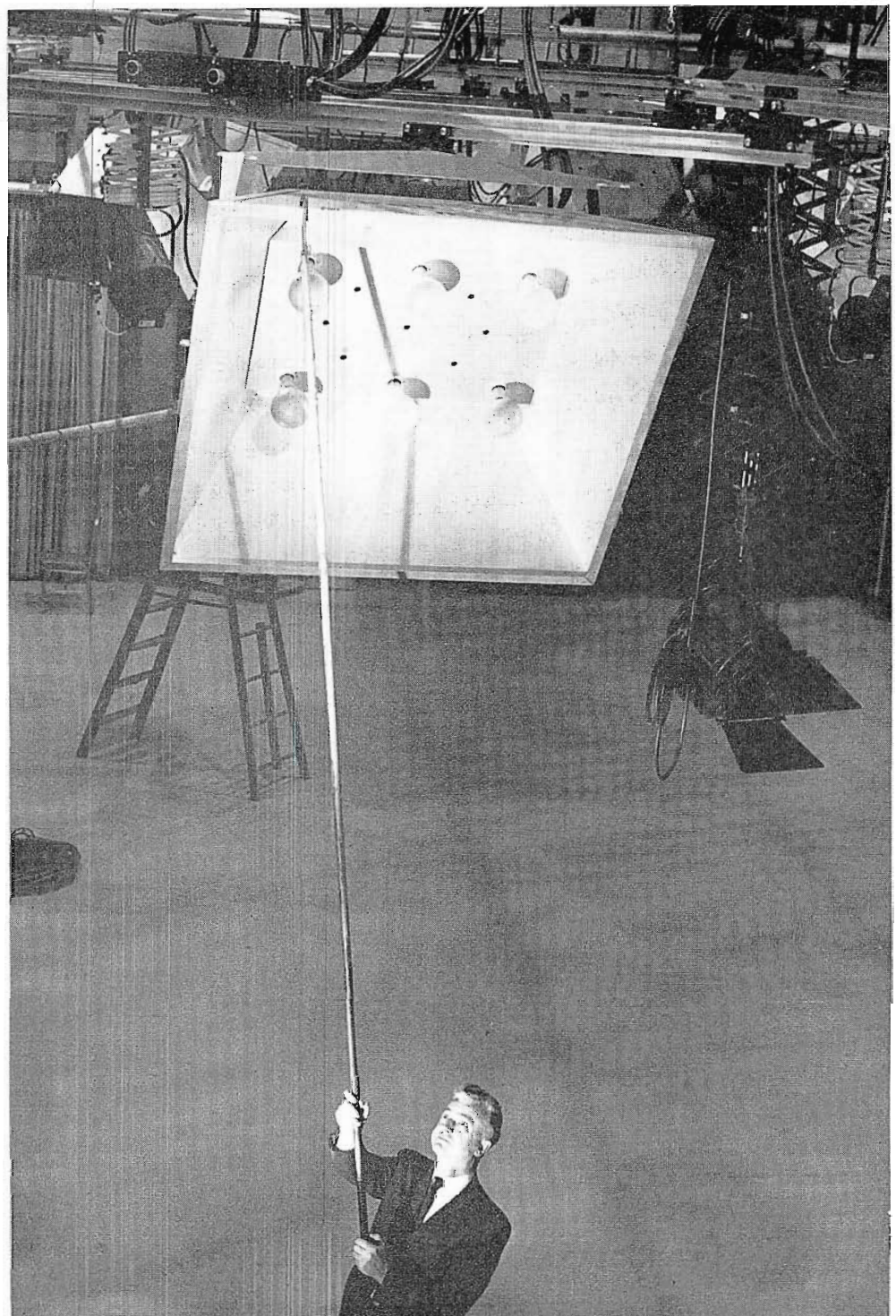
#### Studio Philosophy

Design of the TV studios reflects advanced thinking in this area as conceived by engineering Vice-President Meyers. All three main studios are similar in size and construction, have identical equipment, can handle color as well as monochrome. Facilities are such that each studio can accommodate anything from a 60-second commercial to a full-scale production, with room for audience of 150 people, orchestra and talent, crews with their gear, and large vehicles or other apparatus.

#### Studio Lighting

An unusual method of lighting has been designed by the WGN engineering staff. Instead of scoops, the base lighting is supplied by brute-force "lighting tubs". Designed and built to WGN specs, these are square boxes, 4 by 4 feet, containing sockets for six 1000 watt bulbs. Seven of these tubs are used in each studio.

FIG. 12. Woodrow R. Crane, chief engineer WGN-TV, positions "lighting tub" from studio floor.



In addition, there is the normal complement of spots and floods, both floor and pantagraph mounted, for fill-in, back lighting, and other effects. A total of 120 kw is available for lighting in each studio, and 72 kw of this is on dimmers. Incidentally, the tubs can be dimmed up and down. Thus, each studio has lighting adequate for monochrome and color programs.

To make the lighting arrangement as simple and flexible as possible, all the lights are mounted on fixtures which run on overhead rails. A special fixture was designed by WGN engineers for the "lighting tub", so that they could be propelled into position and tilted at any angle—without the necessity of lowering them or using a ladder. In fact, all the lights can be manipulated from the floor by one man, using a pole.



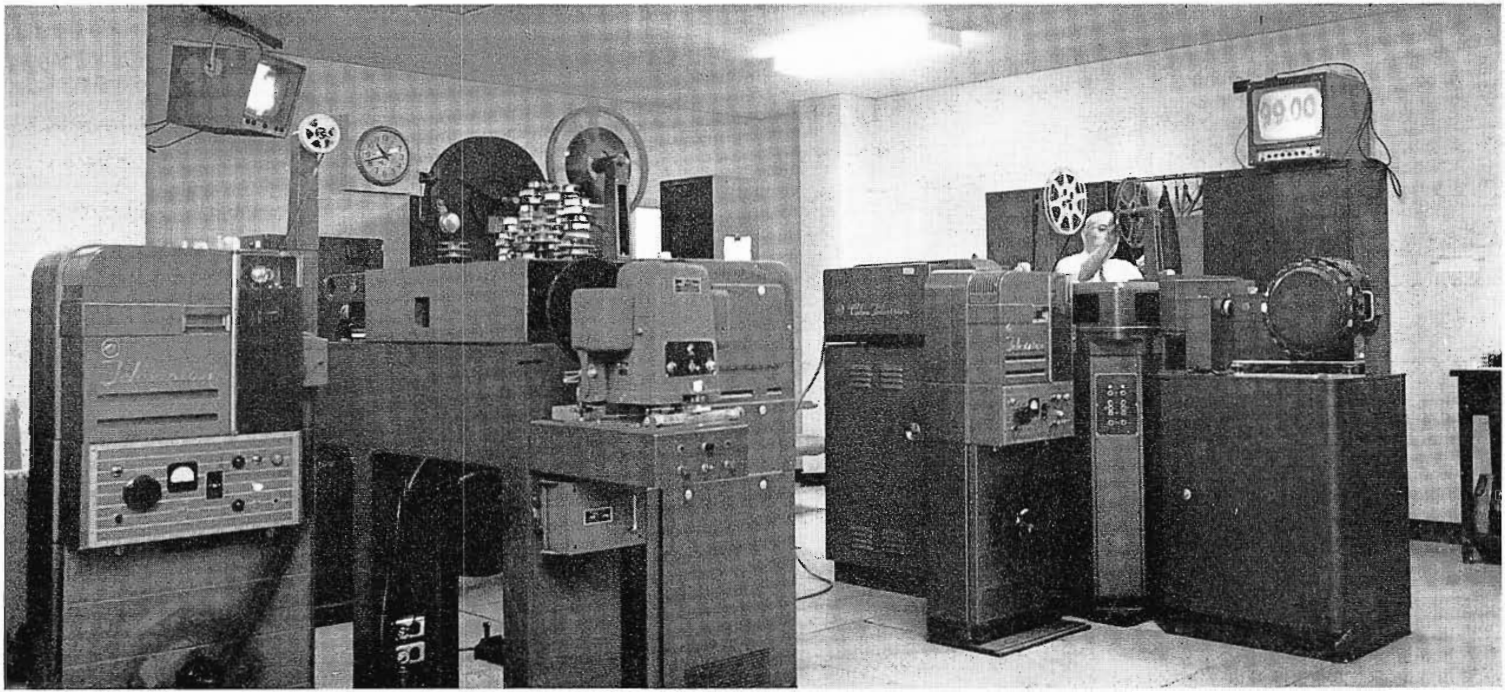


FIG. 14. Film room has two monochrome systems similar to one at left, and one color TV film system (right).

### Color Studios

Each of the three 47-by-72 foot studios may be employed for color. All have necessary facilities for lighting and camera connections. A camera patching panel in master control permits use of monochrome or color cameras in any studio. Suitable color backgrounds are available for use, and in addition a 2-curtain cyclorama runs entirely around the three usable walls of each studio. The two curtains are separated by a distance of approximately two feet. They are of suitable shades for use as color or monochrome backgrounds.

### Color Facilities

The WGN complement of color TV equipment includes 7 live color TV cameras, Type TK-41, 1 Color TV Film System with TK-26 Color Film Camera, a Color TV Mobile Unit, and complete test and transmitter facilities for color. Also, there are microwave links between studio and transmitter, and from mobile unit to studio and transmitter. Both links are TVM-1 equipment—designed for color TV operation. Thus, WGN is equipped to produce color commercials and color programs both in its studios and in its remotes, as

well as to transmit color over microwave and to broadcast it over the air.

### Color Film Facilities

In the film projection area, WGN is handsomely equipped. There are five separate film systems installed and operating. Two IKE chains are used with Balopticans for the handling of opaques. Two vidicon chains are used for black and white films and slides. Each is equipped with a TK-21 Vidicon Camera, a TP-11 Multiplexer, a TP-3 35mm Slide Projector, a 16mm and a 35mm motion picture projector. One has a TP-6 16mm projector, the other a TP-16.

Color movies and slides are handled by the TK-26 film system. This includes a TP-15 Multiplexer, TK-21 Vidicon Camera, TK-26 Color Film Camera, 2 TP-6 16mm Film Projectors, and a TP-7 35mm Slide Projector. With this equipment the station can adequately accommodate any combination of film requirements. Also, there is sufficient space for expansion.

### Master Control

Conveniently situated between film projection and video tape areas, as well as adjacent to studio control rooms, are master switching and camera control functions.

The master control area is arranged so that there are separate positions for the separate functions. One central panel is used for all switching of live, film, tape and remote programs. Shading of five film cameras (including the color film camera) is handled at the film position. Video control of 8 TK-11 cameras is accomplished at the monochrome camera control. At color camera position are controls for the 7 TK-41 cameras.

FIG. 13. Control room, 15 ft. above studio floor, gives good visual coverage of studio.





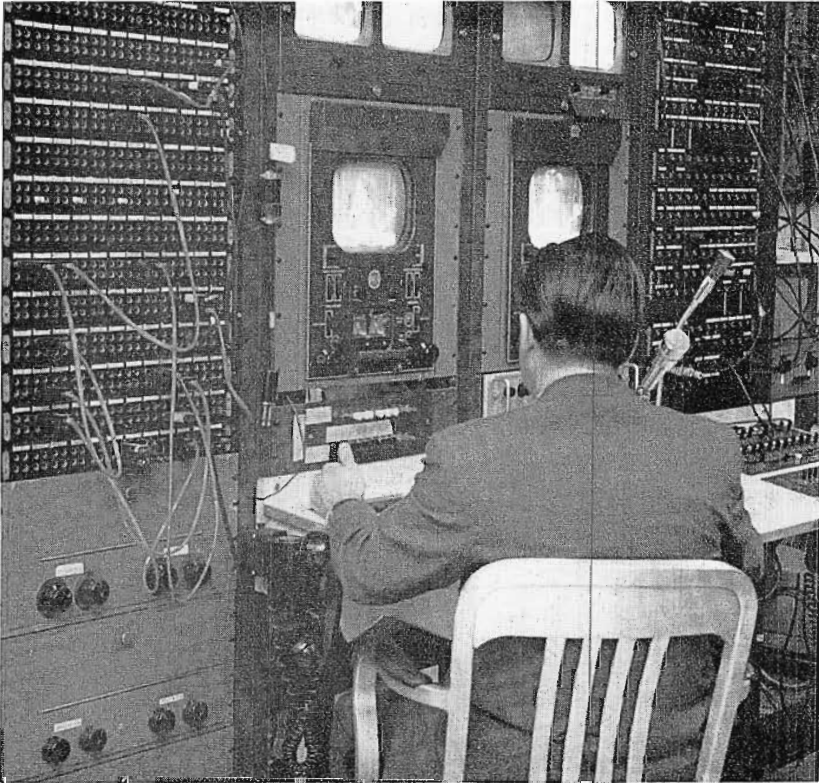


FIG. 15. Master switching for WGN television. In the master control area each function has a separate set-up.

FIG. 16. The four live studio color cameras are controlled here. ▶

FIG. 17. (upper right) Patching panel in master control permits use of any combination of color or monochrome cameras in each of the three studios.

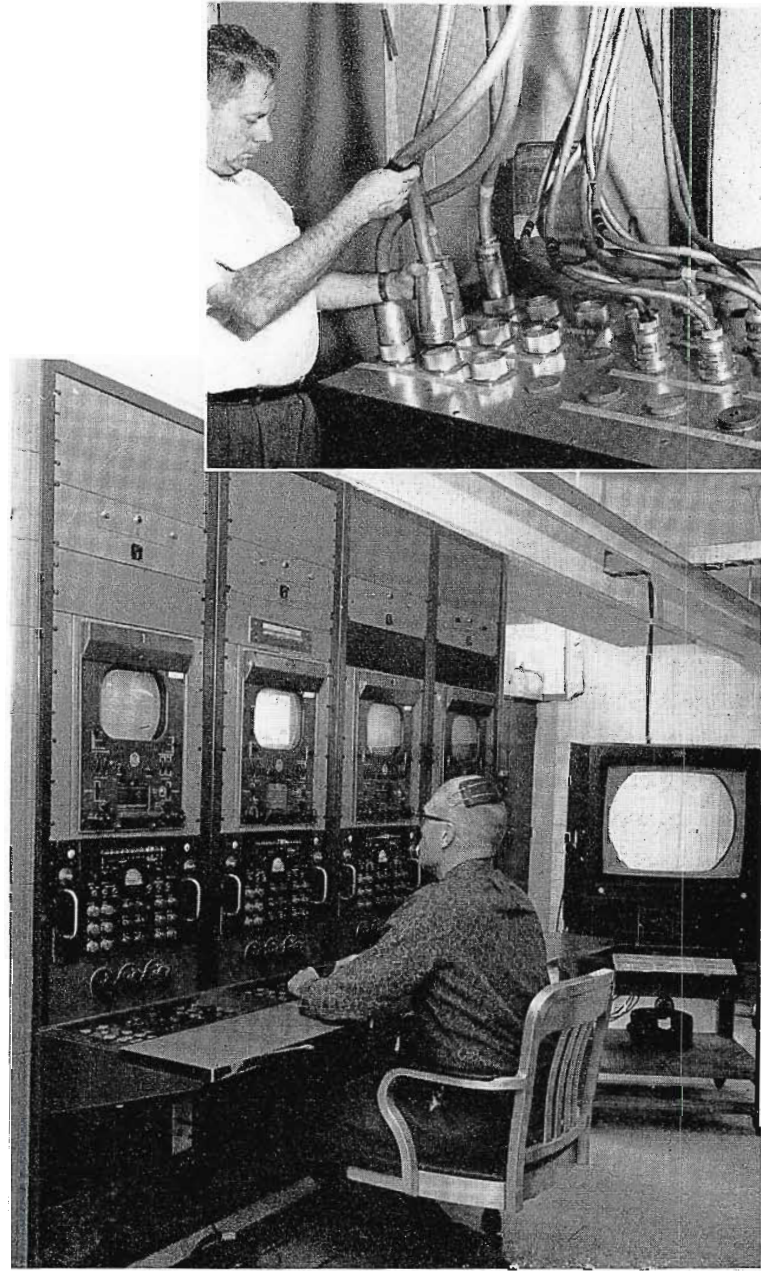


FIG. 18. Position for shading of film cameras in the master control area.



FIG. 19. Eight TK-11 cameras are adjusted from this position in master control.





FIG. 20. Turntable in floor and studio facilities in corner of garage are suitable for automobile and agricultural commercials.

FIG. 21. Type TT-50AH 50 kw TV Transmitter is used by WGN. Together with 12-section superturnstile this gives station maximum of 316,000 watts erp.





### Studio Equipment

Normally there are three TK-41 color cameras in Studio 1, three TK-11 cameras in Studio 2, and three in Studio 3. There are two TK-11 cameras in the routine studio (Studio 4) and 2 TK-11 cameras in the garage studio.

The routine studio is an area 30 by 16 feet used for two-minute newsbreaks, live spots, announcements, etc. The garage studio is an area 50 by 100 feet, featuring a turntable that can accommodate automobiles, tractors, trucks, and other heavy equipment for programs or commercials. It's complete with cyclorama and overhead lighting grid.

Also stored in the garage is the WGN complement of mobile equipment.

### Mobile Units

WGN has two radio news wagons equipped with audio tape and portable equipment for radio broadcasts. Also two complete TV units for making monochrome telecasts. And, a tractor-trailer combination equipped for making colorcasts.

Each mobile TV unit includes 3 TK-11 cameras with field controls and field switching equipment. Also portable microwave for transmission to either the studio or the transmitter. The color unit accommodates 4 TK-41 color cameras and is used extensively for the Chicago White Sox professional ball games. It also includes a TVM-1 microwave link.

### TV Transmitter and Antenna

The television transmitter is located on the 4th floor of the Prudential building in downtown Chicago. WGN uses a TT-50AH 50-kw TV Transmitter with a 12-section Superturnstile Antenna to give the station the maximum of 316,000 watts E.R.P.

Adjacent to the transmitter room on the 40th floor is a small film projection room and a small live studio. Also included are microwave links with studio and remote units, and switching facilities for programming directly from transmitter.

The 73-foot superturnstile antenna is higher than any other structure on the Chicago skyline, extending 914 feet above ground level. The antenna is mounted upon a unique 311-foot tubular steel tower, which is based on the 39th floor roof of the Prudential building.

The giant supporting tower, tapers in diameter from 10 feet at its base to  $3\frac{1}{2}$  feet at its top, scales 200 tons and consists of 23 tubular steel sections welded together. The 20-ton base plate is bolted to the structural steel framework of the building on the 39th floor. The tower is hollow, equipped with doors and ladders for ease of travel to the antenna.

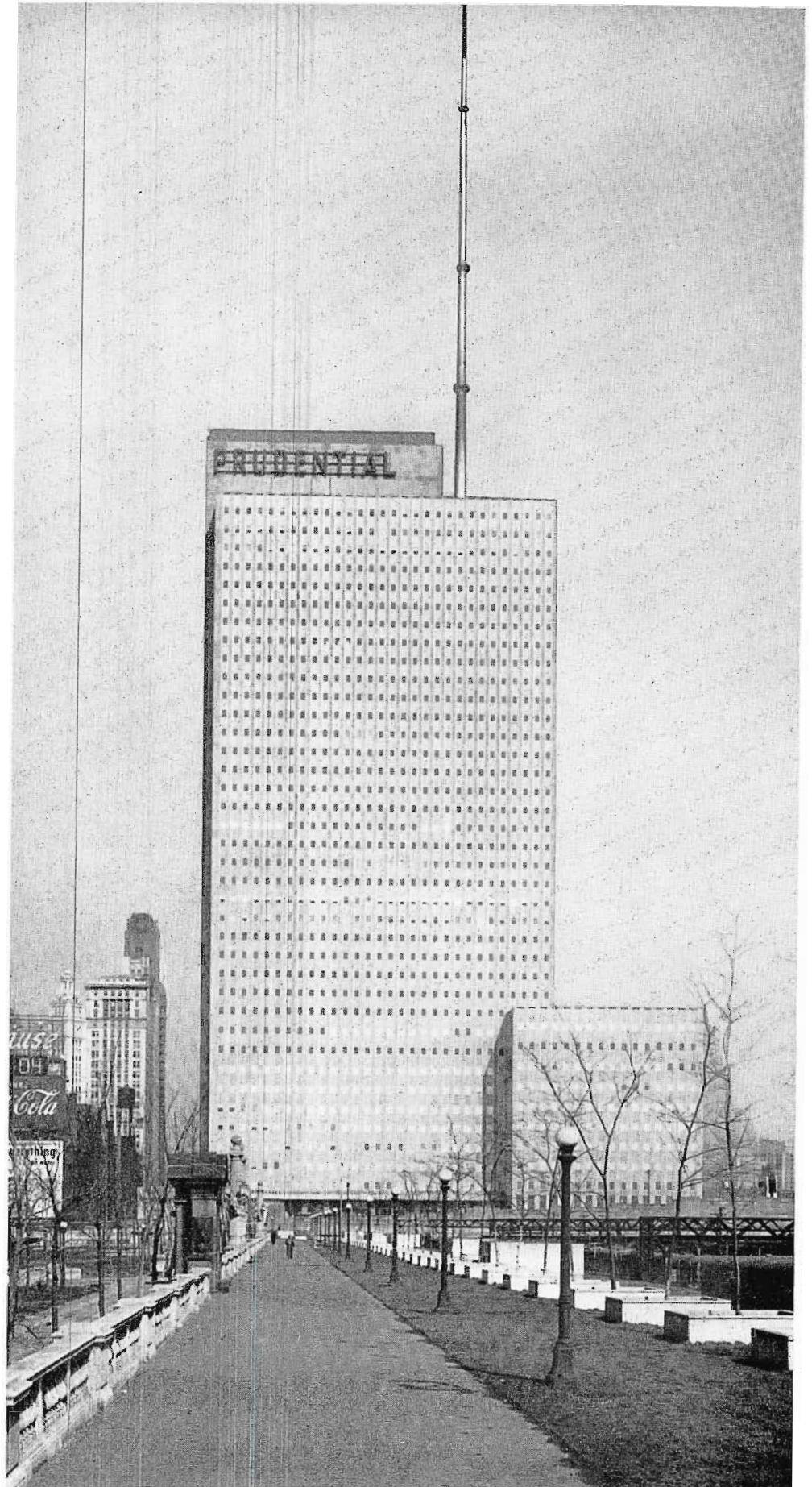


FIG. 22. Prudential building in downtown Chicago houses WGN television transmitter. It also supports attractive tubular steel tower with superturnstile antenna.



## WGN Radio

The new home of WGN contains two radio studios, each 30 by 18 foot, together with adjacent control and announce areas. Should large areas be required for radio programs, use is made of one of the TV studios.

WGN radio transmitting equipment is located on a 100-acre plot near Roselle, Ill., some 22 miles west of the new building. It is reached in a 30 minute automobile drive over a superhighway from the studio. This is an unattended operation with supervisory remote control from the Prudential building.

The radio station employs a Type BTA-50G 50-kw AM Ampliphase transmitter, one of the first of this unique type, in-

FIG. 23. Radio studios and production facilities are also accommodated in the new building.

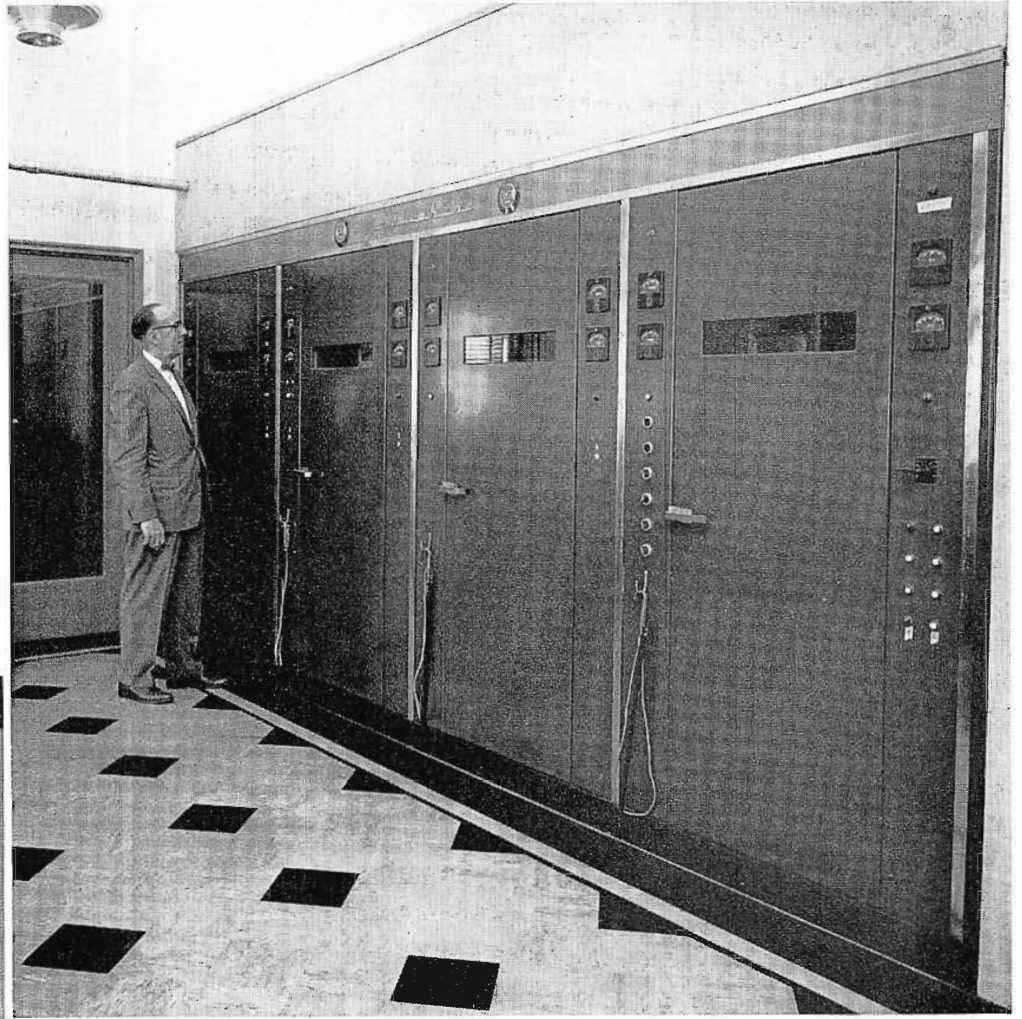


FIG. 24. WGN uses BTA-50G 50 kw Ampliphase transmitter. (It occupies same area required by former 10 kw transmitter.) Radio transmitter is remotely controlled 24 hours a day. (Shown is G. William Lang, Chief Engineer, WGN Radio.)

stalled in December, 1957. A 5-kw transmitter is available for standby use. Both main and standby transmitters are remotely controlled from the TV transmitter area in downtown Chicago.

The main radio antenna consists of a 750-foot guyed tower, located 900 feet from the transmitter building. A standby antenna tower 250 foot high is also installed. The station has been on the air from this location since March, 1939. However, WGN radio had its beginning long before—on June 1, 1924.

### Emphasis on Color

For more than one third of a century, WGN has served the middle west, in terms of information and entertainment, at first in radio, then in television. During the past few years, the station has become one of the foremost pioneers in local color tv, in its continuing effort to serve the public interest. As vice-president Quaal puts it, "We believe in color television because it is better television."



# How WBTV Gets Extra TV Tape Headwheel Life

by F. F. BATEMAN  
*Technical Operations Manager, WBTV*

Recently WBTV logged its 5000th hour of RCA television tape recorder operation from its studios at One Julian Place in Charlotte, North Carolina.<sup>1</sup>

During these first 5000 hours, WBTV has been getting excellent headwheel life. In our two present machines, we have averaged 348 hours on headwheels which have run to the normal end of life. The average life of all headwheel assemblies used (including those taken out of service because of mechanical defects, etc.) has averaged 238 hours per unit. To date, seven separate headwheel assemblies have racked up over 300 hours each.

## One-Man Responsibility

How does WBTV get such good life from the headwheel assemblies in use here? We believe that this is due primarily to the fact that one man has been given responsibility for operation and maintenance of the television tape recorders since the first machine was installed. This man is on a daytime shift. He does the bulk of the tape recording, and during the time the machines are not in use, his time is spent in preventive maintenance. Presently, all our technical operations personnel are checked out on use of the tape machines, but one man continues to have primary responsibility for the condition of the equipment.

The man chosen for this particular job must be one who has a feeling of responsibility, who understands and respects the equipment, and has the initiative required to accomplish adequate preventive maintenance. This, of course, involves tube checking on a fairly routine basis and continual close observation of the equipment while in normal operation.

## Cleanliness Important

Cleanliness is also important in obtaining satisfactory head life. The television

tape recorders at WBTV are installed in an air-conditioned room which helps keep dust problems at a minimum. The operator cleans the headwheel and vacuum guide assembly each time a half-hour or hour tape is played on the machine, and he also takes care to clean lint from the air intake around the edges of the headwheel motor where the cooling air enters.

## Dual-Standards on Tip Penetration

Since roughly 90 per cent of the taping we do is for our own use in-the-house, we have established a dual-standard operation in regard to tip penetration on recording.

When taping for shipment out of the station, or for keeping indefinitely, we follow the proposed SMPTE standard of operation. The eccentricity between the vacuum guide's center of curvature and the headwheel axis of rotation has a value of 0.0003 inches, and tip penetration is set approximately equal to headwheel tip protrusion. This condition is determined by use of the RCA MI-40771 test tape.

We keep the hours of use fairly well balanced between the two machines, which means that the two headwheel assemblies are continually accumulating about the

same number of hours total wear. This allows us, when taping for in-the-house playback within a few days, to limit tip penetration on recording to 2 mils beyond the drop-out point (as long as the headwheel tip protrusion exceeds 2 mils). Naturally, when the headwheel tip protrusion has worn down to 2 mils, our in-the-house recording is done from then on according to the proposed SMPTE standard.

While most of our tape operation does not involve tip penetration over about 2 mils, all tapes made for outside use or for indefinite storage are fully compatible with the proposed SMPTE standards. We feel this philosophy of operation contributes materially to our good headwheel life record.

## Equipment Reliability

In summary, it would seem that the good headwheel life obtained at this station is due first, to the assignment of one particular man of high qualifications to operation and maintenance of the recorder; second, to cleanliness in operation and maintenance of the equipment; and, third, to use of minimum necessary tip penetration when recording.

The RCA television tape recorders which have been in use here for over two years have proved to be extremely dependable and reliable in operation. There has been, of course, the normal amount of maintenance to be expected from such a piece of electronic equipment. However, the basic design of the television tape recorder has proved itself in our day-to-day operations.

FIG. 1. The author, Frank Bateman, inspects one of the tv tape headwheel panels. In 5,000 hours of operation, WBTV has averaged 238 hours per panel, including those still in service. Seven separate headwheel panels have racked up over 300 hours each.



<sup>1</sup> EDITOR'S NOTE: WBTV installed its first television tape recorder in September of 1958 when it took delivery of one of the seven preproduction models of the recorder built by RCA. This recorder was in extensive use in on-the-air programming at WBTV until June of 1959 when it was replaced by a production model. The first RCA production television tape recorder, TRT-1AC, was received at this station May 22, 1959 and put in service on the same date. The second production model television tape recorder, TRT-1AC, was received and put in service on October 4, 1959. Both recorders are in extensive use in day-to-day studio operations at the present time.



# KFVS-TV TRANSMITS FROM WORLD'S TALLEST STRUCTURE

Traveling Wave Antenna Atop 1676-foot  
Tower Covers 32,000 Mile Service Area

On September 1, 1960, KFVS began operating from the tallest tower in the world. The station is reaching almost 2,000,000 people living in the approximately 32,000 square mile area covered by the signal being radiated from the new tower. This is probably one of the largest TV patterns ever produced. The null-fill characteristics of the Traveling Wave Antenna have made structures of this height practical without sacrificing "close-in" coverage.

#### Tower Construction

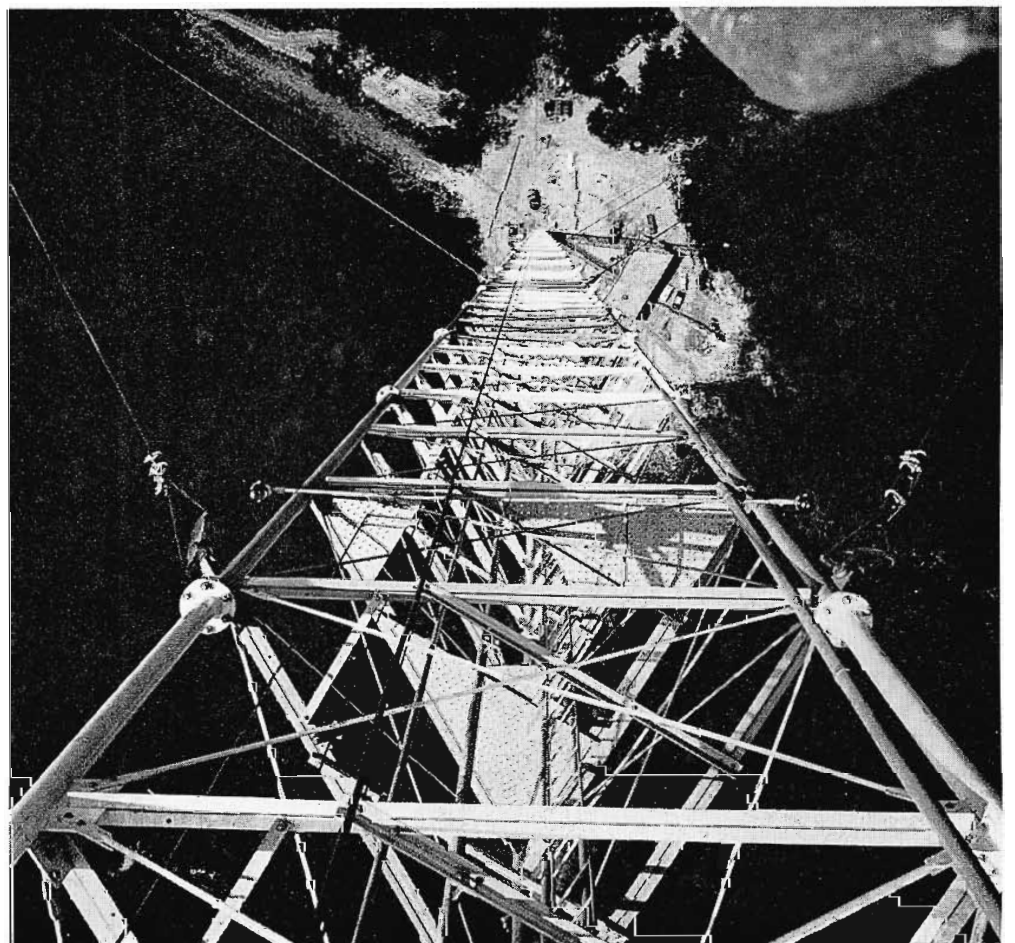
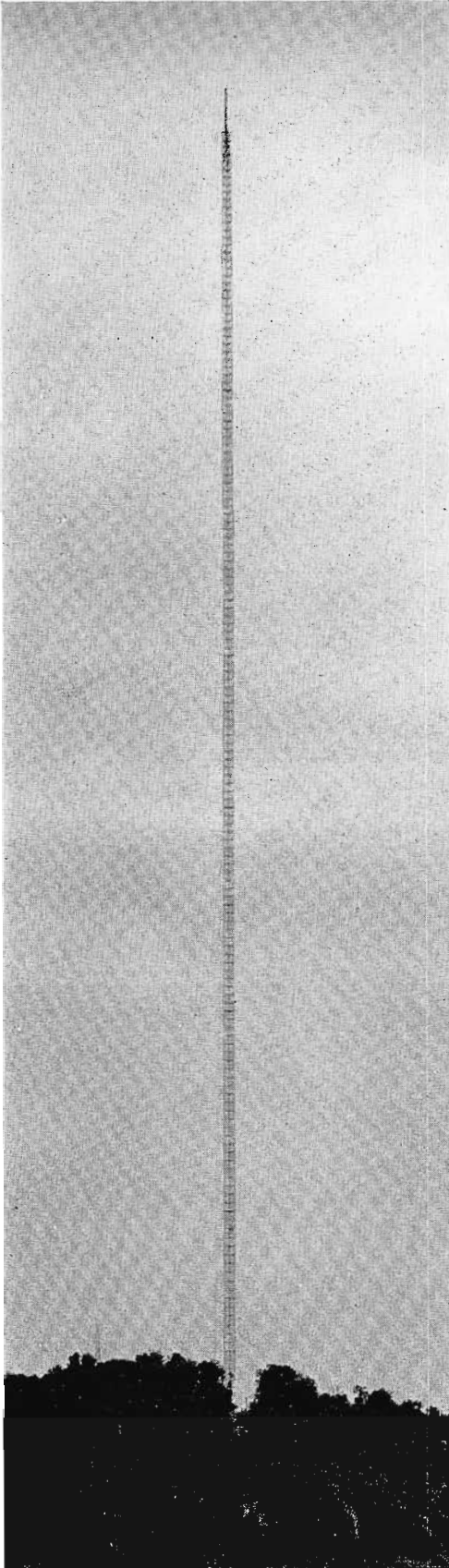
Foundations for the tower and guy anchors were put in place March, 1960.

These reinforced concrete foundations withstand a pressure of over 2,000,000 pounds. On April 15th the first steel section was assembled and the final section was in position by July 20. The tower legs are solid steel rods that vary from  $7\frac{1}{2}$  to 4 inches in diameter. Cross bracing between legs is with heavy steel angles and rods.

The 30-foot tower sections were assembled and painted on the ground before being hoisted aloft and bolted into place. A crew of 15 riggers erected the entire structure, including the  $5\frac{1}{2}$  ton Traveling Wave Antenna.

FIG. 1. World's tallest man-made structure. New, 1676-foot television tower in Cape Girardeau, Mo., for station KFVS-TV is 204 feet taller than Empire State Building, 692 feet taller than Eiffel tower.

FIG. 2. View from top of world's tallest structure. An 81-foot traveling wave antenna is used by station KFVS-TV to beam television programs to more than 2,000,000 people living in a 32,000 square mile area.



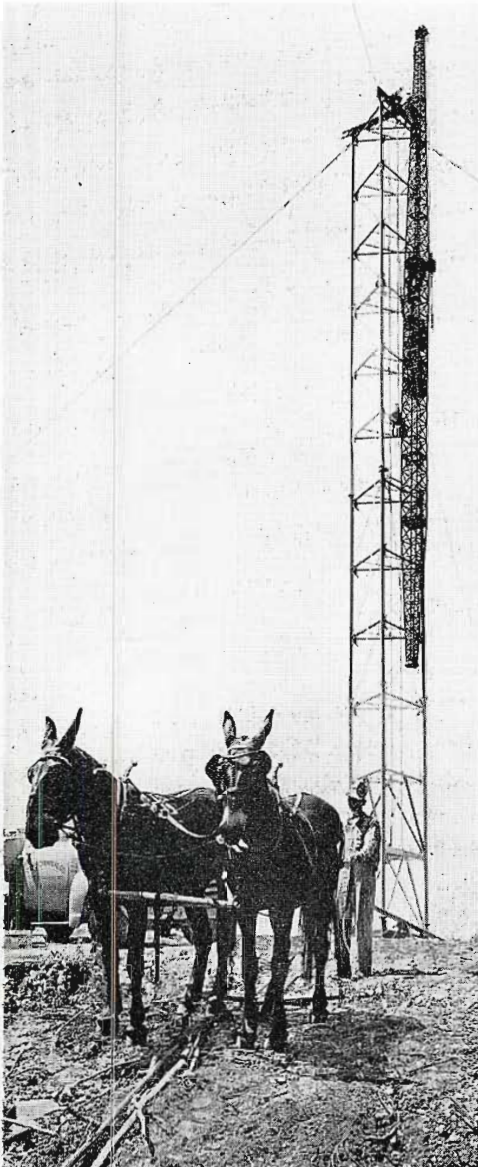


### Longest Elevator Ride

A passenger elevator enclosed within the tower takes 25 minutes to reach the top . . . the longest, highest elevator ride in the world. Although it can provide some unforgettable thrills for guests of the station willing to ride to the top, the elevator is being used mainly for maintenance of the big structure and antenna. It is also used to carry maintenance crews up the tower to change bulbs in lights and beacons, and to repaint the tower periodically. An outside platform located at the top of the tower, and eleven smaller platforms located within the structure, provide work and rest areas for the maintenance crews.

The tower and antenna are painted in alternate bands of white and aviation red, each 30 feet high, to make them clearly visible during daylight to aircraft cruising

FIG. 3. Missouri mules help build world's tallest structure. Because of rugged terrain at site of KFVS-TV tower mules had to be used in placing the bottom ends of guy cables that support the structure.



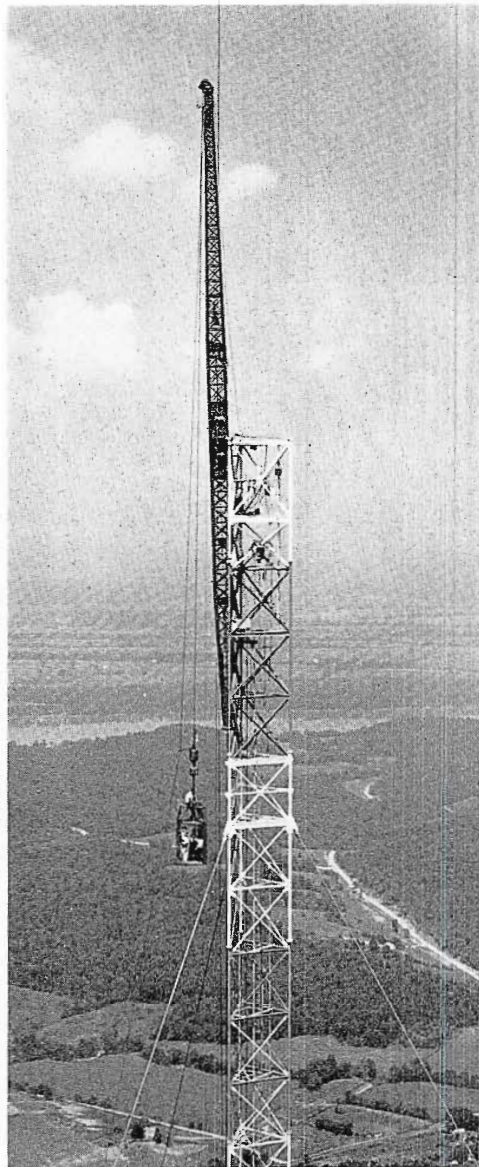
in the area. Five giant 1000-watt flashing red beacons are located on the tower . . . one at the top and the others positioned at intermediate levels throughout its height. Between the big beacons, a series of smaller red lights burn with a steady glow. The lighting system turns on automatically at dusk, or when clouds envelop the tower.

For emergency use in the event of an elevator breakdown, a ladder runs from the ground to the top of the tower. If a man could be found with the stamina to make the climb, it is estimated it would take about three hours.

### Simplified Antenna

The 81-foot tall Traveling Wave Antenna is mounted atop this amazing structure. Since the Traveling Wave Antenna is of very simple construction, it requires little maintenance—an important factor at

FIG. 4. At the site, 30-ft. sections were assembled and painted on the ground then hoisted aloft and bolted into place. Special hoisting equipment used consisted of a heavy boom (gin pole) that "walked" up the tower as it grew.



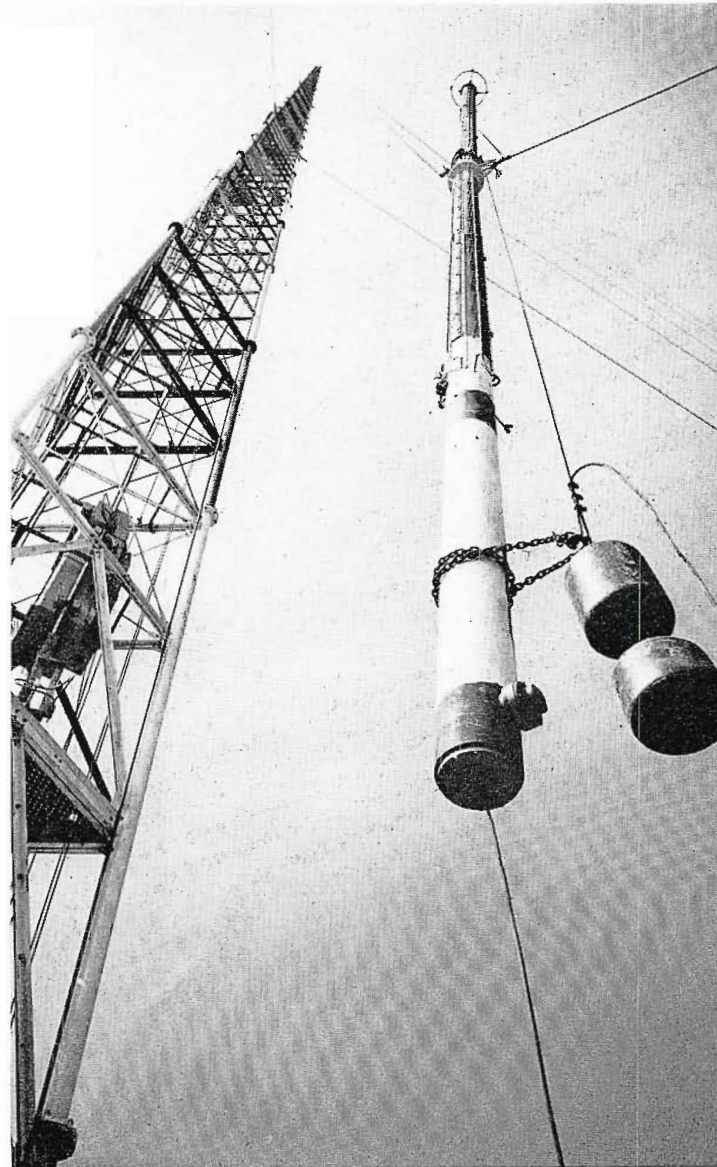
1676 feet. The antenna is basically an extension of the transmission line with specially designed slots to radiate the signal. Design of the antenna accounts for the excellent null-fill characteristics of the Traveling Wave Antenna.

A second factor in KFVS selection of the Traveling Wave Antenna is its ability to withstand winds up to 100 mph. High mechanical strength in both the tower and the antenna are vital to the safety of the structure at this extreme height.

Thus, the Traveling Wave Antenna fulfills all requirements of both safety and simplicity to radiate the maximum effective power for the KFVS-TV fabulous coverage area.

Photos courtesy of Dresser-Ideco Co., designer and fabricator of the new tower.

FIG. 5. Eighty-one foot traveling wave antenna is last part to be hauled to top of tower. This, too, was assembled and painted on the ground. KFVS-TV now gets more than twice its former coverage.

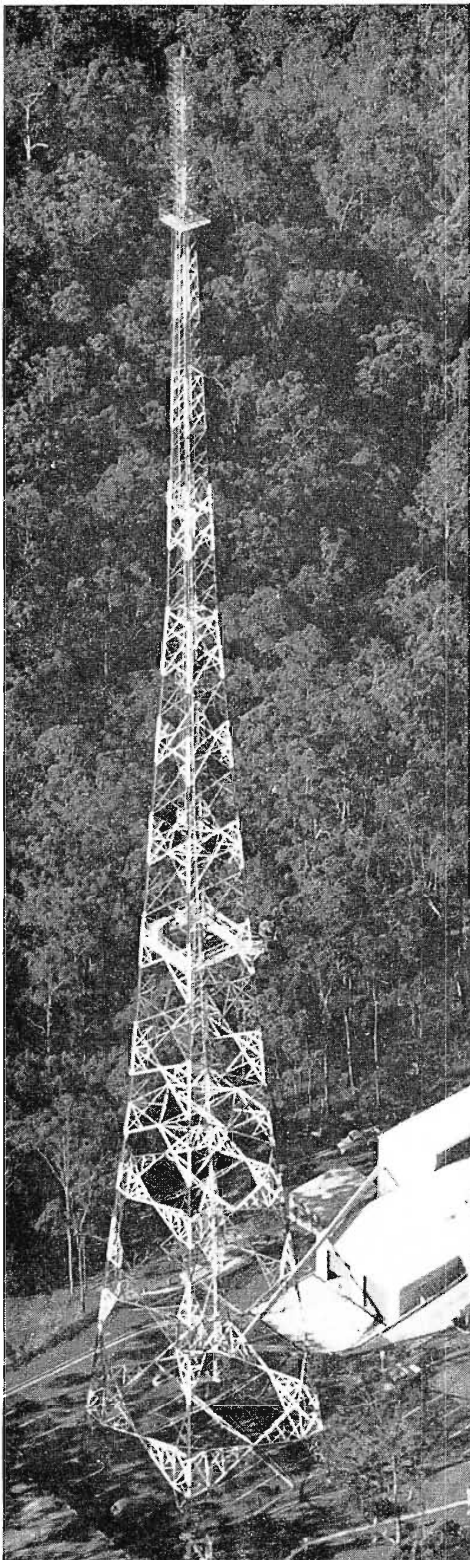




# QTQ

## AUSTRALIAN TV STATION DEDICATED TO EFFICIENT COMMERCIAL OPERATION

by ROSS THYER, *Chief Engineer QTQ-9*



Less than one mile from the summit of Brisbane's beautiful Mt. Coot-tha, an imposing green building and slender steel tower blend gently into a landscape of carefully planned gardens and lush subtropical forest. QTQ, Channel 9, each week broadcasts seventy-six hours of entertainment. Comprehensive tape, telecine and live programme facilities bring quality

presentation of the best recorded material together with an active participation in local live variety to the 880,000 population of metropolitan Brisbane.

On November 28, 1958 the Australian Postmaster General granted to Queensland Television Limited a licence to operate a commercial station in the Brisbane area.



FIG. 1. James William McKay, General Manager, QTQ.



FIG. 2. Ross Thyer, Chief Engineer, QTQ.

Under Chairman of Directors, Douglas Wadley, a General Manager, James W. McKay, and Chief Engineer, Ross Thyer, were appointed in January, 1959.

The station commenced commercial operation in August, 1959, and since this time has been closely associated with ATN, Channel 7, in Sydney, GTV-9 in Melbourne and NWS-9 in Adelaide, in the production and distribution of Australian variety, drama and sporting programmes.

Plans are now well advanced for an inter-city cable and microwave link system between the state capitals Adelaide, Melbourne, Sydney and Brisbane and the national capital, Canberra. This cable has already been laid from Sydney as far north

FIG. 3. Partially completed QTQ building. Studio B can be seen in the foreground in the center of the picture. Studio A will extend over the staff car park shown in the right of the picture.



as Maitland and to the south almost as far as Canberra. The cable also extends northward from Melbourne to Bendigo. Three-hundred and fifteen miles of cable have been laid since January, 1960. The inter-city co-ax is being installed on behalf of the Australian Postmaster General's Department and will be used by both Government-owned and commercial television interests. The television relay facility between Sydney, Canberra and Melbourne is scheduled for completion by June, 1963.

### Studio and Transmitter Building

At Television Centre, both studios and transmitter are accommodated on a three-and-a-half acre site. The difficult excavation for the building foundations commenced late January and was completed only two weeks later. Erection of steelwork commenced on March 20, and a completed technical and service building was handed over to the QTQ engineering department early in July, and the station was transmitting test patterns before the end of the month.

Building construction was carried out by Messrs. Stuart Bros. Pty. Ltd., of Sydney and Brisbane, and the attractive building was designed by architects, Havens & Kirkwood, in association with Guy Crick, Lewis and Williams of Brisbane and Sydney.

The building is a steel frame structure with six-inch reinforced concrete flooring. Interior infill partitions are constructed from four-and-a-half inch brick plastered on both sides. Exposed exterior walls up to ground level are eleven-inch cavity brick. The major exterior portion of the building is clad in pressed zinc anneal sheets. The completed structure with a floor area of 37,500 square feet has five levels including a roof-top canteen and a small sub-basement.

The architects utilised the natural fall of the site to accommodate a four-storied structure with a minimum of basement excavation work. The building was designed around an integrated single level technical area below a functional ground floor production area. The concept of QTQ is a classical example of the building block principle as shown in the floor plans, Figs. 4 and 5. This technique allowed progressive completion of Stage 1, technical and service area; Stage 2, Studio B, and Stage 3, administration block.

### Studio B

The 50 by 70-foot Studio B has splendid access to an 8300 square foot service area. A central corridor runs the full length of

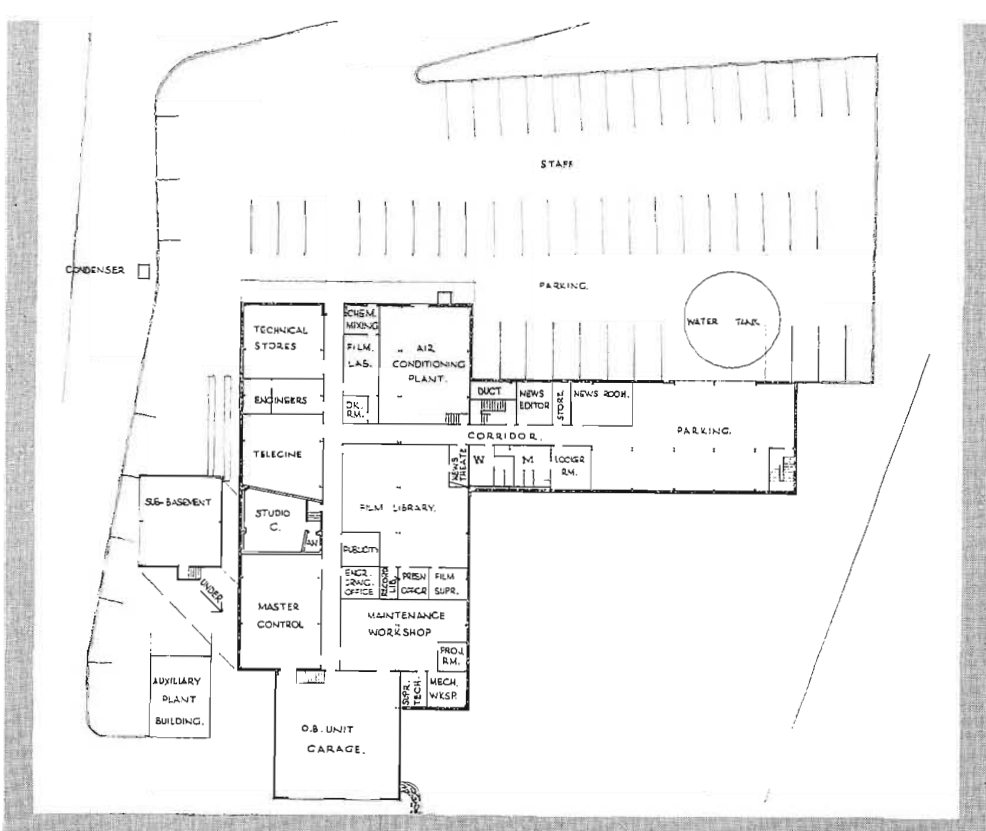
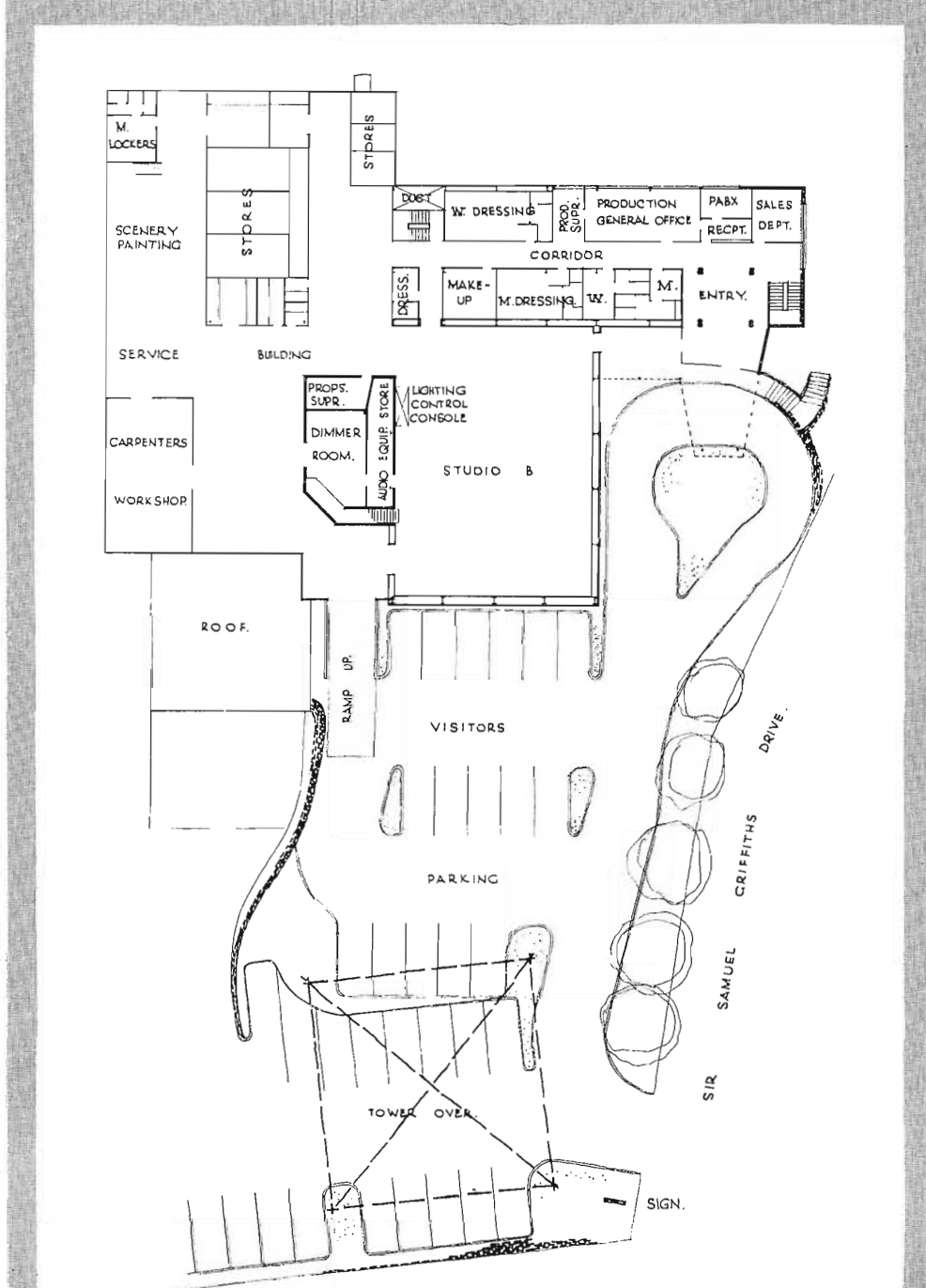


FIG. 4. The layout of the Central Technical Area can be seen clearly in the architect's simplified basement floor plan.

FIG. 5. The ground floor plan shows the layout of the spacious Service Building, Studio B, Dressing Rooms and adjacent offices.





the administration block between the foyer and service building, giving access at ground level to make-up dressing rooms and Studio B. The waiting audience is accommodated under the awning, between the porte cochere of the south wall and the main studio. The special audience door precludes the possibility of interference with traffic from other areas.

The 42-foot high Studio B shown in

The 20 by 170-foot blue cyclorama curtain, woven in one piece, runs on a special track around two walls of the studio to cover the lighting battens' winches and the motor driven scenery winches. A catwalk aids high level lighting and provides access to overhead running gear and the cyclorama track.

A 104-circuit lighting control console uses a rotary patching system in conjunc-

tion with 15 5-kw saturable reactor dimmers. Twelve sub-master dimmers and 3 master groups provide maximum flexibility in the control of 24 2-kw spot lights, 50 high-efficiency 750-W spot lights, 46 1-kw scoops and a 5-kw spot. Two pattern projectors and miscellaneous ground row and supplementary lighting make for an adequately illuminated studio.



FIG. 6. Popular Australian television personalities, Bob Dyer and Graham Kennedy appear before the Studio B Cameras during the first anniversary of "BRISBANE TONIGHT".

Fig. 6 has 6-inch thick reinforced concrete floor overlaid by 1-inch thick magnesite. The outer walls of pressed zinc anneal sheeting are insulated initially by 3 inches of slagwool. A 1-foot air space divides the outer wall from 1-inch fibrous plaster sheeting with set joints pinned on to timber framing. The inner wall comprising a 1-inch slagwool blanket encased in wire netting has resulted in the desired acoustically dead character of the studio. Artificial reverberation can be introduced by a magnetic disc delay device inserted in series with selected microphone inputs. A high degree of sound isolation is provided, although seldom put to test in the low ambient noise conditions found on the mountain.

Studio B is equipped with three TK-31 cameras mounted on one TD-10 and two TD-3A pedestals, see Fig. 7.

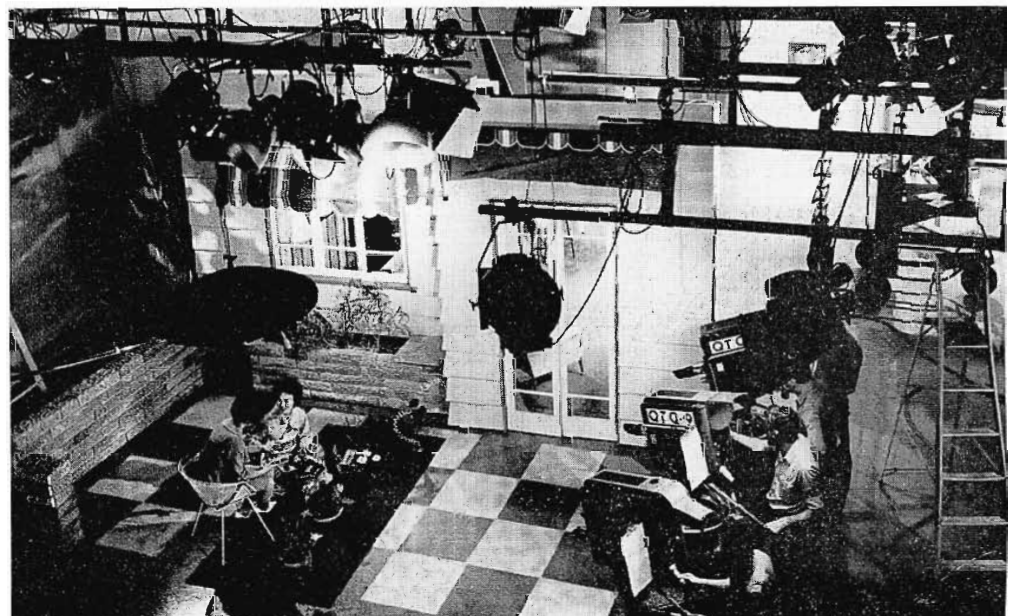


FIG. 7. Studio B is 50 feet by 70 feet and has a winch driven flying batten grid with twenty-six lighting battens and nine scenery battens.





FIG. 8. From left to right in the Studio B control room, we see the script assistant, director, vision switcher and technical director.

FIG. 9. The control panels for TS-40 switcher and special effects system are shown in the Studio B control room. The panel above the special effects selector includes camera intercom and studio talkback facilities for the technical director.



Local staging requirements call for a base light illumination of 100 foot candles with key lighting as high as 140 foot candles. The close-spaced target image orthicons in the cameras give low noise pictures with an average lens opening of f8.

#### Studio B Control Room

The programme director sits at a 3 by 11 foot main control desk, 8-feet-6-inches above the studio floor and 10 feet from a double glazed window, see Fig. 8. This control room window is 4-feet-6-inches high and 23 feet long so that the director's eye subtends a vertical angle of 30 degrees from the high level monitors and the closest action on the studio floor.

To the right of the TS-40 switcher control panel shown in Fig. 9, is the comprehensive technical director's talkback and technical monitoring facilities. The 5-bus TS-40 switcher has 8 video inputs and is used in conjunction with a TA-25 special effects system to provide considerable flexibility in control of programme inputs.

The audio control position (Fig. 10) is situated to the left of the director in a 9 by 15 foot totally enclosed booth. Here a BC-6B dual audio console is supplemented by a 4 channel auxiliary mixer. On the BC-6B, 9 input fader functions together with key switching, provide facilities for 10 microphone inputs, 2 telecine, 2 turntables, 1 audio tape, 1 tv tape, audio, and remote inputs. The normal complement of microphones for this studio includes 4-BK-5, 4 77-DX, 3 BK-1A and 8 BK-6B.

FIG. 10. The BC-6B console in the Studio B audio control room is sometimes supplemented by a four channel auxiliary mixer (not shown).





### Central Technical Area

The QTQ central technical area is located in the basement below the studio service building. All basement technical areas have direct access to a corridor which runs the full length of the building between the garage and the basement-level staff entrance, at the eastern end of the building.

### Studio C

This compact presentation studio is intended for news and weather telecasts

together with simple interview programmes and small scale commercials. The studio, see Fig. 11, is equipped with fixed news and weather sets, fixed lighting battens and a simple lighting control system. Two walls of the studio can be covered by use of the multiple curtain track supporting a variety of special drapes designed to give the best results with a remotely operated TK-21 vidicon camera.

A large double glazed window with a special acoustic damper box provides ade-

quate sound isolation and an excellent view into the master control room. The studio is equipped with a TK-21 vidicon camera mounted on a heavy duty remote pan and tilt unit and fitted with a remotely controlled Berthiot zoom lens. The 5 remote functions of the Studio C camera (pan, tilt, zoom, iris and focus) are operated from the master control technician's console. The general illumination level of 250 foot candles has been found to produce excellent results from the vidicon camera with a normal lens opening of f4.

### Telecine

In the spacious telecine room, two TK-21 cameras are mounted on TP-11B multiplexers and have three optical inputs. Each multiplexer is used in conjunction with two 16mm projectors and one TP-7A

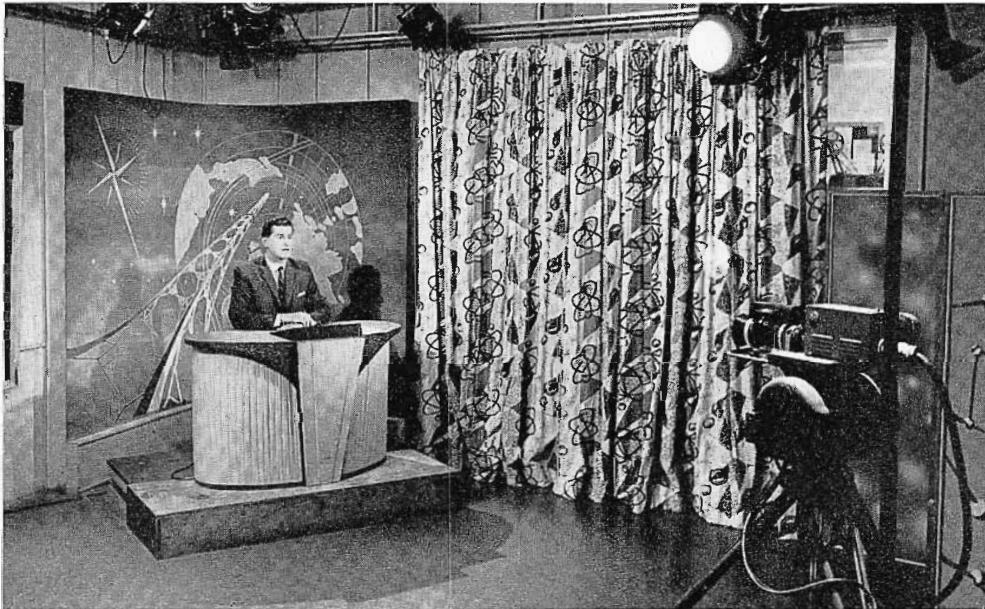


FIG. 11. Studio C is 21 feet by 21 feet and is used for the presentation of News and Weather Bulletins together with simple live commercials and interview-type programmes. This Studio is equipped with a TK-21 vidicon camera used in conjunction with a zoom lens. The camera and lens have complete remote control of pan, tilt, focus, iris and zoom. Preset lighting and the special camera facilities allow for unattended operation in this Studio.

FIG. 12. Master Control serves a three way function as Studio C control room, transmitter control room and master control room. The RCA TS-40 switcher and BC-6B audio console provide flexible programme control facilities.





dual drum slide projector. Both film and slide projectors can be remotely operated. A delegate switch mounted on the vidicon console will transfer this facility between Studio B and master control. A television tape recorder is also housed in this room.

### Master Control

Master control has been conveniently located in the northwest corner of the building for easy access to the engineering workshop and with direct access through double doors into the remote vehicle garage. During the initial planning, the decision was made to site the transmitter together with all video and audio terminal equipment within one area.

The transmitters and associated equipment are installed to the left of the master control desk. This desk and operator's console face a window into Studio C (see Fig. 12). The master control desk normally accommodates a master control operator, the presentation director and an audio operator. During news segments the pre-

FIG. 13. QTQ-9's 497 foot tower 16-stack dipole panel antenna, fed by dual transmission lines through two power dividing and impedance changing transformers. Each half of the antenna can be energised separately.

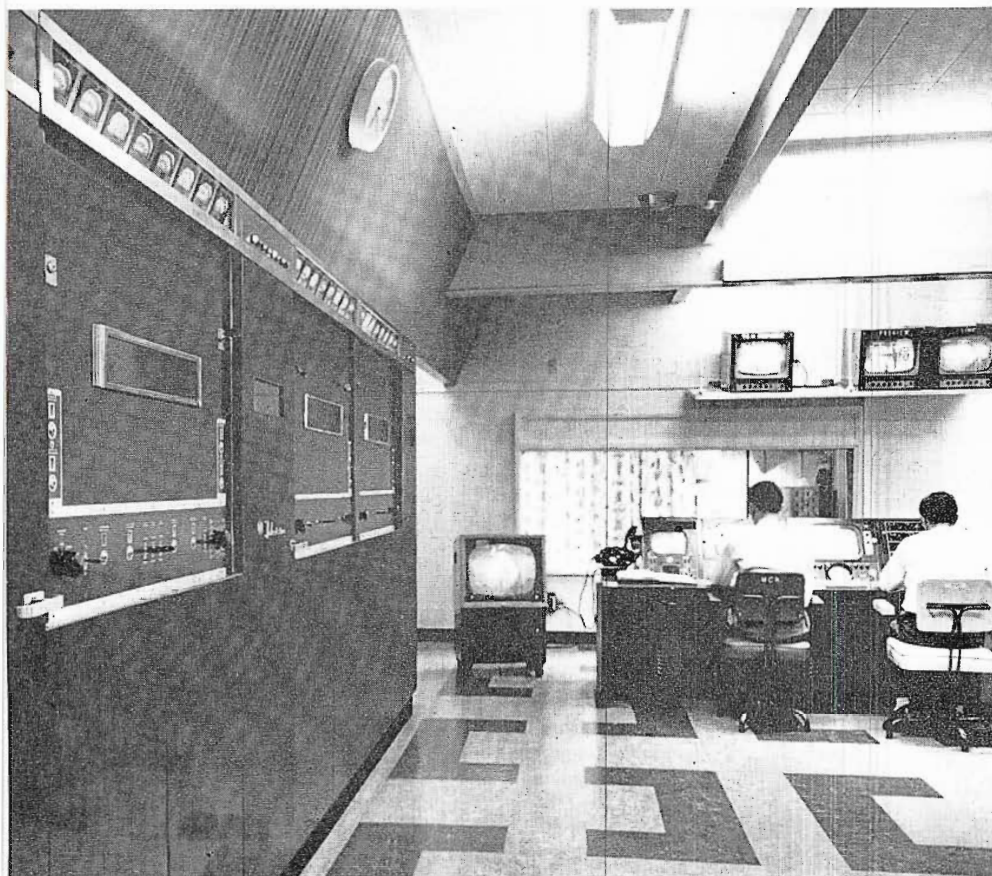
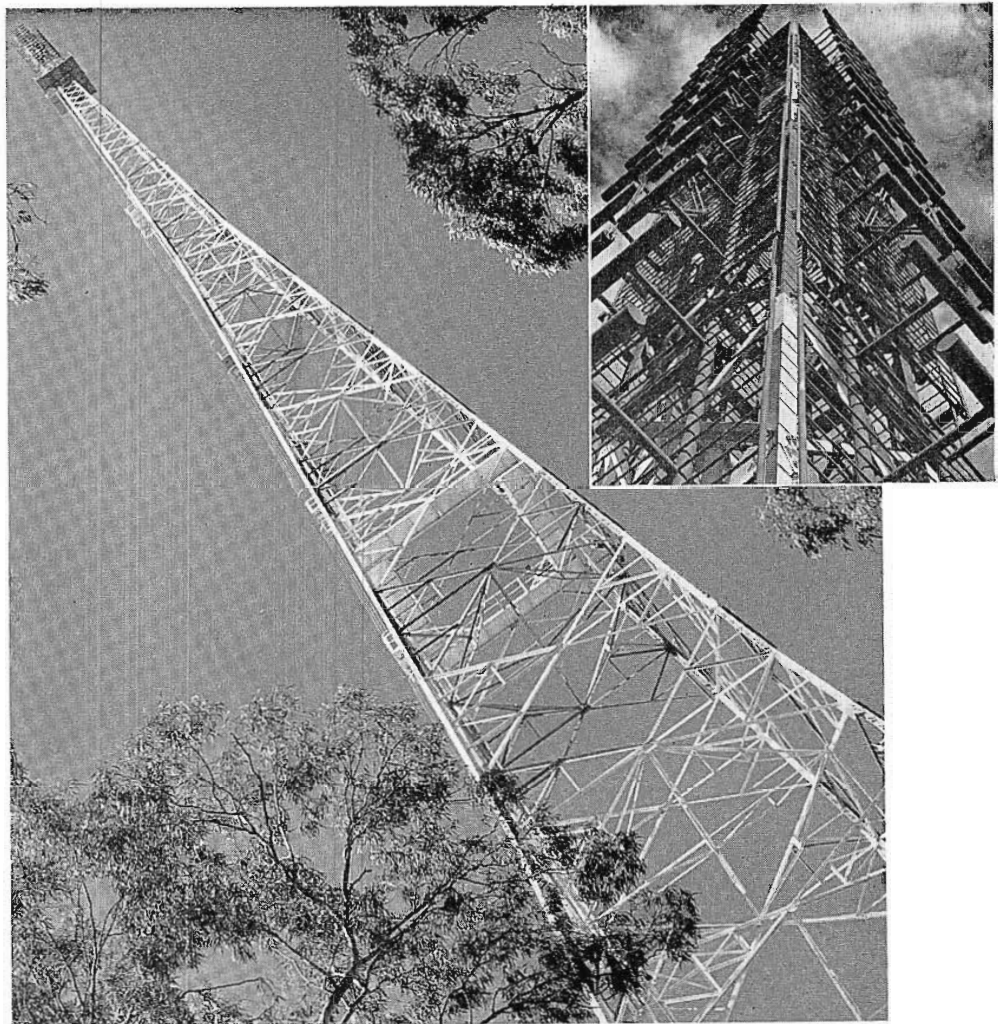


FIG. 14. The TT-2BH standby transmitter and the TT-11AH main transmitter allow for uninterrupted programme transmission. Changeover is facilitated by coaxial switches.

sentation director is assisted by a member of the news department. A TM-6 monitor is permanently connected across the vision demodulator and is mounted in a 13-inch console housing. To the right of this, in a 22-inch console housing, a 14-inch monitor is switchable between the output of a TS-2 transmitter monitor switcher and the output of the TK-21 Studio C vidicon camera. The technical preview facility is provided by a TS-11 mixer displayed on another 14-inch monitor. To the right of the master control operator, a TS-40 switcher control panel is mounted. A BC-6B consolette is mounted to the right of the TS-40, and the audio operator's control desk is extended to accommodate two turntables.

### The Transmitters

The main transmitter is a Type TT-11AH. Used with a 16 stack dipole panel antenna, see Fig. 13, the combination gives



an effective radiated power of 100 kw. A 2-kw TT-2BH is used to provide a standby facility. Changeover between the main and standby transmitters is accomplished by means of remotely operated coaxial switches. The high tension circuits of the transmitter not in use are held open by the external interlocks. Using this method and running the alternative transmitter with heaters on, the changeover function is executed in less than one second. The separate VSB filter and notch diplexer are mounted vertically on the north wall of the master control room behind the transmitters. Six motor-driven co-ax switches and two 7-pole manual transfer panels allow flexible control of the transmitter outputs. Either of the two transmitters can be fed via the VSB filter and notch diplexers through the power dividing tee to the combined aerial or alternatively the notch diplexer and the tee can be by-passed, feeding the visual output to the top half of the antenna and the aural output to the lower half of the antenna. This function is facilitated by co-ax switching. The manual transfer panels enable the main transmitter to be run up into the 10 kw dummy load whilst the standby unit is on air. In addition the combined output from either transmitter can be fed into the upper or lower half of the antenna.

### The Antenna

The 16-stack dipole panel antenna has a nominal gain of 12 and is fed by 22mm styroflex from 2 power dividing and impedance matching transformers. Dual 3/8-inch diameter solid copper feeder is used to feed the 2 transmission line trans-

formers. The horizontal section of the transmission line between the central technical area and the base of the tower is supported on a 110-foot braced steel truss.

Total height of the tower structure is 497 feet. Extensive use has been made of high tensile steel and the weight of the tower has been kept below 100 tons. Undercut foundations are used to engage a greater frustrum of earth and reduce the weight of concrete in the tower base. The self-supporting structure has been designed to withstand a wind velocity of 95 mph at ground level.

### Outside Broadcasts

The TJ-70A television mobile unit will accommodate 4 image orthicon cameras together with the necessary accessory equipment. The 1½ ton air conditioning unit keeps interior conditions within the comfort zone in spite of high ambient temperature and humidity encountered in Queensland. Adequate power for equipment and lighting is provided by a 25-KVA diesel 3-phase alternator fully enclosed in a custom-built soundproof trailer.

The vision switcher in the TJ-70A is a TS-5A. Audio is handled by a BC-5A console. Dual sync generators and genlock facilities are provided by two TG-12A's.

The facilities provided by the TJ-70A remote unit are supplemented by a single camera roving remote built around a Volkswagen Kombi. This vehicle has a self-contained power supply and is able to transmit pictures while on the move. Both units are pictured in Fig. 15.

During the last two years the station has presented 64 outside broadcasts of events such as football, basketball, hockey, boxing, wrestling, tennis, swimming, diving, water-skiing, sailing, rowing, baseball, athletics, motor-racing, horse racing, surf carnivals, parades and variety spectacles. Possibly the most colorful remotes have been those involving sailing in Moreton Bay and on the Brisbane River. These telecasts were carried out with the aid of a zoom equipped camera and a microwave link mounted on a launch, see Fig. 16. The 4-foot tripod mounted parabola was fitted with a special sight to facilitate visual alignment with the shore-based unit. Under conditions of heavy swell and from shorter distances, a horn antenna was used.

Due to the undulating nature of local terrain and also because of the great distances involved in many of the telecasts, extensive use has been made of self-contained microwave link repeater stations. Such an installation is shown in Fig. 17.

A TF-55A rotatable mount with a 6-foot parabola is mounted at the 200-foot level of the tower, see Fig. 18. Remote controls in the master control facilitate rapid alignment on to a link bearing. All QTQ remote vehicles, including the news van, are fitted with radio telephones. The programme department has allocated a special frequency for this communication link. The base station has been situated at the 200 foot level on the tower to prevent feeder losses and to derive the maximum range from the 50 watt transmitter. An inverted ground plane dipole antenna mounted below the microwave link platform provides

FIG. 15. Mobile equipment includes: TJ-70A mobile unit, 25 KVA diesel generating set, Volkswagen Kombi, fitted out as a Roving Remote. The other vehicles are the news department station wagon and engineering tender unit.







FIG. 16. A TVM-1A microwave link with 4-foot reflector and TK-31B Image Orthicon camera with zoom lens are seen mounted on a launch during a remote telecast of the 18-Footer Sailing Championships on the Brisbane River.

FIG. 17. A microwave link repeater station installed on Eagle Heights near the famous Gold Coast area of Queensland. This repeater station was being used to facilitate the telecast of the Rosebowl Tennis Tournament at Southport.



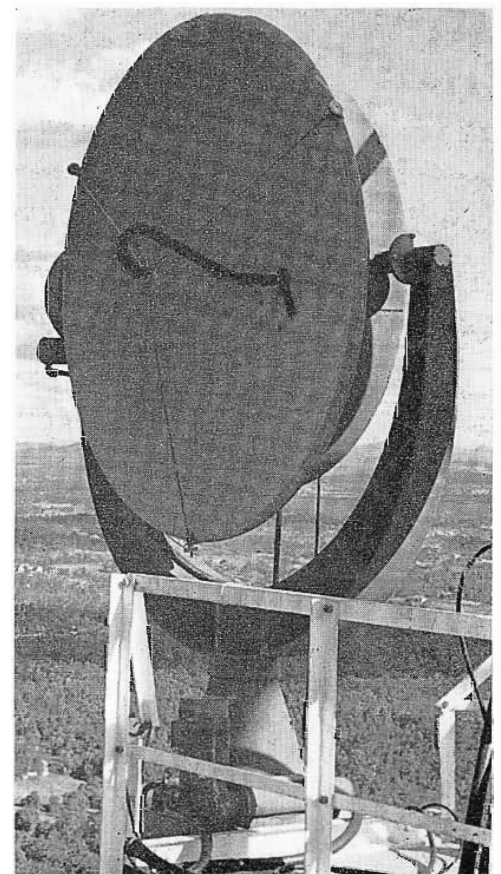
excellent coverage for the communication link within the Brisbane metropolitan area.

#### Future Expansion

The QTQ building has been designed to allow extensions to the north, to the east and upwards. The service area can be extended to accommodate the future Studio A, at the same time providing additional space in the technical area below. Studio A will extend to the east over the staff car

parking area. The layout of the central technical area is ideally suited to automation and from the master control room an operator has an unobstructed view to Studio C, telecine and the master control announce booth. Considerable additional space has been allocated for the ultimate addition of color which, because of the stringent requirements of the Australian Broadcasting Control Board promises to be of the highest technical standard.

FIG. 18. A TF-55A rotatable mount with a 6-foot reflector can be seen on the 200-foot level on the tower. The unit is remotely controlled from the master control room.





# NEW MICROPHONE-AMPLIFIER TYPE BN-10A

A VERSATILE UNIT ESPECIALLY  
DESIGNED FOR REMOTE BROADCASTS

by ROBERT REYNOLDS  
*Broadcast Audio Marketing*



FIG. 1. The BN-10A is ideal for remotes and interviews. It is complete with monitoring facilities and power supply.

In continuing effort to bring forward new and useful tools to satisfy the needs of today's broadcasters, RCA now offers a combination Microphone-Amplifier complete with built-in power supply. Here in one complete, compact unit are all the necessary items to successfully accomplish a single-microphone remote broadcast—microphone, amplifier, earphone monitor, and line cord.

The BN-10A Microphone-Amplifier consists of a BK-6A dynamic microphone, a sealed transistor amplifier, a long-life mercury battery, phone jack and line connection socket. All are neatly and conveniently contained within an aluminum housing, measuring only  $11\frac{3}{4}$  inches in length and  $1\frac{1}{8}$  inches in diameter. The total weight of the BN-10A, including the battery, is only 13 ounces.

A plastic, zippered carrying case supplied with each microphone-amplifier holds the BN-10A, its 30-foot line cord (with amplifier plug attached) and a miniature earphone. Thus the unit is always ready to go when you are.

Operation of the BN-10A is simple and effortless—one end of the line cord is connected to the remote telephone loop, the other end is plugged into the unit. Nothing else is required—no meters to read, no bothersome connections to make and, what is more, no waiting for warm-up, since insertion of the line cord plug turns on the amplifier battery power. Furthermore, the operational simplicity of the BN-10A makes it an ideal remote unit for use not only by the experienced station engineers but by non-technical personnel as well.

The well-known BK-6B miniature dynamic microphone is the heart of the BN-10A microphone-amplifier. The excellent field-proven pick-up characteristics of the BK-6B are preserved, amplified and delivered to the output of the BN-10A by a completely sealed, transistor amplifier unit. The amplifier delivers a  $+6VU$  to a 600-ohm load under normal speech conditions with distortion less than 3 per cent from 70 to 15,000 cps. Life of the mercury battery, as used in the BN-10A is rated at 50 hours. Thus, over 500 five-minute periods of use, or over 150 fifteen-minute periods of use, could be accomplished with excellent economy. Battery replacement is easy and may be performed in a few minutes time. The outer shell of the unit is

unscrewed from the base and slid forward, the old battery removed and a new one snapped into place.

The compact design, light weight, and excellent quality of the BN-10A makes it an excellent choice for the broadcaster to complement his existing multi-channel remote broadcast equipment. Many remote program originations today can be handled by single microphone pickup. Often times this means tying up a four-channel remote amplifier and a microphone which could be seeing service elsewhere, not to mention the time required by personnel to set up the remote system. This, then, is but one of the cases where the BN-10As simplicity of installation and operation will be immediately apparent.

The usefulness of the BN-10A is not confined, however, to remote broadcasts, it can well be the necessary solution to the requirements of an extra microphone channel in a studio consolette during a multi-microphone type of program. The high output level of the BN-10A can be fed directly into a high-level mixing input on the studio consolette. Thus this low-cost versatile instrument can be employed with success for both studio and remote applications.

FIG. 2. View of BN-10A with protective barrel removed to show construction and elements.

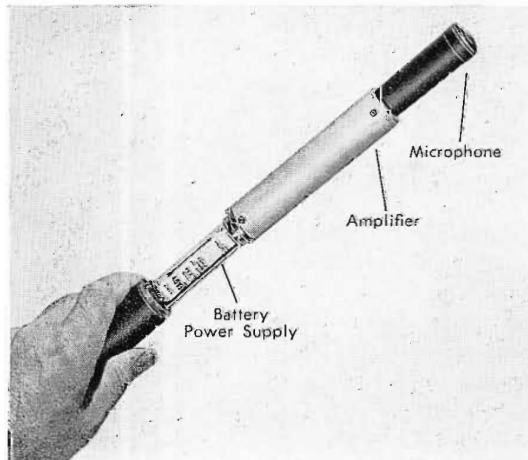
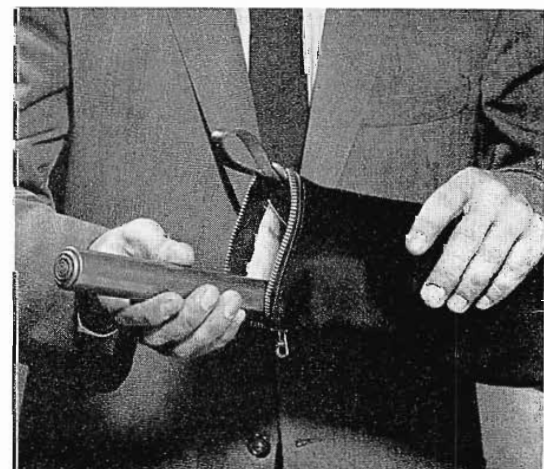


FIG. 3. The complete microphone-amplifier combination—together with earpiece, jack and 25-foot cable—is carried in a small zippered bag.







## RCA TV Microwave Spans 136 Miles in a Single Hop!

### New TVM-1B Equipment Carries TV Signals

### Over Great Salt Lake To KID-TV, Idaho Falls

Engineered by RCA specialists, this single-hop Microwave system transmits TV programs from a 9000-ft. mountain peak near Salt Lake City . . . traveling across the length of Great Salt Lake, and through a mountain pass to the receiving point in Idaho, 136 miles away. From there the programs are distributed via another RCA Microwave link, 89 miles long, to station KID-TV in Idaho Falls.

"We're getting the kind of superior performance and reliability that one might expect from short-hop studio-to-transmitter links," reports Carroll Secrist, KID-TV Chief Engineer. "The new TVM-1B equipment has been in operation since January 1961. A series of measurements recently made indicate: video signal-to-noise ratio (PP/RMS) . . . 64db; audio signal-to-noise ratio . . .

greater than 65db. Propagational reliability, conservatively estimated at 99.9 percent, is approaching 99.99 percent."

RCA's new TVM-1B Microwave Relay equipment is designed for maximum performance with reliability and economy in transmission of television programs in black-and-white and color. This superiority of performance and reliability is being proved daily in over 700 TVM systems now in use.

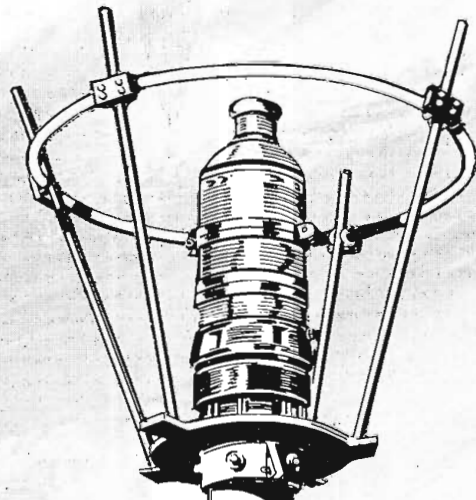
A new RCA TVM-1B Microwave system for your installation may be counted on to accomplish impressive results. Be sure to consult your RCA representative on your microwave plans. Or write to RCA, Broadcast and Television Equipment, Department ZB-22, Building 15-5, Camden, N. J.



The Most Trusted Name in Television

RADIO CORPORATION OF AMERICA





For Ease of Installation  
 Better Protection  
 Uniform Patterns  
 Low VSWR



The Popular Choice of Broadcasters for High Power TV Applications

# RCA "TRAVELING WAVE" ANTENNA

Combines Improved Electrical Characteristics

with Mechanical Simplicity and Economy

Here is a VHF high-band antenna that has inherently low VSWR and produces smoother patterns. The design, based on slot radiators, results in improved circularity. This new antenna is strongly resistant to high winds and offers better weather protection.

The steel outer conductor is hot-dip galvanized for better conductivity and protection. The inner conductor of the antenna is rigidly supported at the bottom end without relying on any insulator type of support to carry the dead weight. Polyethylene slot covers are fastened to the pole over every slot for better weather protection.

## INHERENTLY LOW VSWR

The traveling wave nature of the feed results in a low VSWR along the antenna. This characteristic gives the antenna an inherently good input VSWR without compensating or matching devices. The input has been broad-banded to provide a smooth transition from the transmission line to the antenna.

## SIMPLIFIED FEED SYSTEM

The feed system is completely self-contained with only one point of connection. Simplified feed system consists of a large coax line and coupling probes. Completely enclosed by heavy-wall steel shell, thereby minimizing possibility of damage and off-air time due to "lightning discharges."

## EXCELLENT VERTICAL PATTERN

The null-less vertical pattern is extremely smooth. This provides uniform illumination of the desired service areas. Gains from 9 to 18 can be obtained.

## HOW THE "TRAVELING WAVE" ANTENNA WORKS

Essentially, the RCA "Traveling Wave" Antenna is a transmission line with slots cut into the outer conductor. These slots are arranged to guide the energy radiated by the center conductor into the needed radiation pattern. It fills the need for a VHF High-Band Antenna which combines mechanical simplicity and economy, especially in high-gain, high-power applications.

## IMPROVED CIRCULARITY

The individual patterns produced by slot radiators when added in phase quadrature result in an overall pattern with improved circularity. This design combines radiating elements, feed system and antenna structure in one unit, giving excellent horizontal circularity.

## LOW WIND RESISTANCE

The smooth cylindrical shape of the antenna is ideal for reducing wind load and has high structural strength. It is designed to withstand a wind pressure of 50 psf of flats, or 33 1/3 on cylindrical surfaces. In addition, the absence of protruding elements minimizes the danger of ice damage.

Your RCA Broadcast Representative will gladly help with TV antenna planning. See him for details on this new antenna. Or write to RCA.



The Most Trusted Name in Television





***“So Real  
on RCA TV Tape  
that Food Advertisers  
Buy on Sight!”***

**...SAYS EARL MORELAND, MANAGER, WMCT-TV, MEMPHIS**

“The clarity of RCA Tape commercials has been a big factor in selling time to local and regional food advertisers. Through RCA Tape, WMCT has secured increased schedules and new business. Advertisers can produce commercials on tape faster and more economically than on film. And once they see how real their productions look on RCA Tape, they buy it on sight. We are already producing over 50 commercials a month—and we’ve just started.

“From an engineering standpoint, the RCA recorder was selected because: 1) RCA produces

equipment geared to broadcast requirements, using parts familiar to television engineers; 2) The machine is designed for ease of service; 3) Based on many years’ dealings, the station felt confident that professional assistance from RCA would be readily available should the need arise.”

For information on the finest quality TV Tape Recorder, call your RCA Broadcast Representative, or write to RCA, Broadcast and Television Equipment, Dept. C-129, Building 15-5, Camden, N. J.



The Most Trusted Name in Television





RCA designs and builds the TV cameras and other TV studio equipment that record the action and sound . . .



RCA designs and builds the equipment that transmits the TV signals.



And RCA designs and builds the TV sets, color and black-and-white, that bring the picture and sound into your home. There is an RCA Victor model for every taste and pocketbook.

## RCA takes the picture...sends the picture...and receives the picture! No wonder RCA is the most trusted name in television



When you buy an RCA Victor television set, you can rest assured that you're getting the very finest your money can buy.

For RCA has an unequalled background of experience in every phase of the television industry. In fact, the very same RCA electronic skills, research, and facilities that build everything from

studio cameras . . . to transmitters . . . to the tube you see the picture on . . . combine to bring you the sharpest, clearest television pictures you've ever seen.

From the very beginning of the industry—first in black and white, then in Color TV—RCA has been recognized as the most trusted name in television. Today, more RCA Victor sets are in use

than any other make. Yet important as television is to RCA, it is but one of many fields of electronics in which the Radio Corporation of America is active as a pioneer and leader. TMK(s)®



The Most Trusted Name  
in Television

RADIO CORPORATION OF AMERICA